

HONOAPI'ILANI HIGHWAY IMPROVEMENTS PROJECT,  
WEST MAUI: UKUMEHAME TO LAUNIUPOKO

# Appendix 3.16 Noise – Supplemental Information

December 2024

*Prepared for*



Honoapi'ilani Highway  
Improvements

*Prepared by*





# Contents

---

Noise Technical Report





# Noise Technical Report



# Contents

---

<b>Executive Summary.....</b>	<b>1</b>
<b>Chapter 1 Introduction.....</b>	<b>3</b>
<b>Chapter 2 Project Description .....</b>	<b>4</b>
<b>Chapter 3 EXISTING NOISE ENVIRONMENT.....</b>	<b>7</b>
3.1 THE STATE OF HAWAIʻI DEPARTMENT OF TRANSPORTATION (HDOT) AND THE FEDERAL HIGHWAY ADMINISTRATION REGULATORY CONTEXT.....	7
3.2 METHODOLOGY.....	7
3.2.1 Noise Fundamentals .....	8
3.2.1.1 Decibel Scale .....	8
3.2.1.2 Typical Noise Levels .....	8
3.2.1.3 Noise Propagation .....	10
3.2.1.4 Noise Criteria .....	10
3.2.2 Study Area.....	12
3.2.3 Data Collection Methods.....	12
3.2.3.1 Noise Monitoring .....	12
3.2.3.2 Traffic Noise Model Validation.....	19
3.2.3.3 Results of Existing Noise Measurements.....	21
3.2.4 Existing and Future Noise-Sensitive Land Uses.....	21
3.2.4.1 Existing Conditions .....	21
<b>Chapter 4 Future Traffic Noise Levels.....</b>	<b>25</b>
4.1 PREDICTION METHODOLOGY .....	25
4.1.1 Noise Impact Analysis .....	25
4.1.2 No Build Alternative.....	25
4.1.3 Build Alternative 1 .....	25
4.1.4 Build Alternative 2 .....	30
4.1.5 Build Alternative 3 .....	30
4.1.6 Build Alternative 4 .....	30
4.2 COMPARATIVE ASSESSMENT.....	31
<b>Chapter 5 Noise Abatement Measures.....</b>	<b>32</b>
5.1 NOISE ABATEMENT EVALUATION: 2045 BUILD ALTERNATIVES.....	32
5.1.1 Noise Barrier 1, Build Alternative 4 .....	33
5.1.2 Preliminary Noise Mitigation Findings / Statement of Likelihood .....	35
<b>Chapter 6 Construction Noise Impacts .....</b>	<b>36</b>
<b>References .....</b>	<b>38</b>
<b>Appendix A – Field Data Sheets and Site Photographs.....</b>	<b>39</b>
<b>Appendix B – Long-Term Measurement Data.....</b>	<b>53</b>
<b>Appendix C – Field Instrumentation Calibration Certificates .....</b>	<b>60</b>
<b>Appendix D – Modeled Traffic Data .....</b>	<b>67</b>
<b>Appendix E – Traffic Noise Modeling Data.....</b>	<b>80</b>



## TABLES

TABLE 3-1.	Average Human Ability to Perceive Changes in Noise Levels .....	10
TABLE 3-2.	Noise Abatement Criteria .....	11
TABLE 3-3.	Noise Measurement Data and Traffic Noise Model Validation.....	20
TABLE 3-4.	Predicted Existing Worst-Hour Traffic Noise Levels.....	22
TABLE 4-1.	Predicted Existing Worst-Hour Traffic Noise Levels.....	28
TABLE 6-1.	Construction Equipment Noise Levels .....	36

## FIGURES

FIGURE 2-1.	Project Location.....	5
FIGURE 2-2.	Build Alternatives.....	6
FIGURE 3-1.	Typical Noise Levels .....	9
FIGURE 3-2.	Project Area Zoning, Olowalu .....	14
FIGURE 3-3.	Project Area Zoning, Ukumehame .....	15
FIGURE 3-4.	Project Area Land Use, Olowalu.....	16
FIGURE 3-5.	Project Area Land Use, Ukumehame.....	17
FIGURE 3-6.	Noise Monitoring Locations .....	18
FIGURE 4-1.	Modeled 2045 Noise Levels with the Project.....	27
FIGURE 5-1.	Evaluated Noise Barrier Location, Build Alternative 4 .....	34

## ACRONYMS

ACRONYM	DEFINITION
ANSI	American National Standard Institute
dB	decibel
dBA	A-weighted decibels
EIS	Environmental Impact Statement
FHWA	Federal Highway Administration
HDOT	Hawai'i Department of Transportation
$L_{eq}$	the energy average noise level, in dBA, for a specific time period
NAC	Noise Abatement Criteria
Project	Honoapi'ilani Highway Improvements Project
TNM	Traffic Noise Model



## Executive Summary

The Hawaiʻi Department of Transportation (HDOT), as the state project sponsor and lead agency, in coordination with the Federal Highway Administration (FHWA), the federal lead agency, has prepared a Draft Environmental Impact Statement (Draft EIS) for the Honoapiʻilani Highway Improvements Project (the Project) in accordance with the requirements of the Council on Environmental Quality's (CEQ) regulations for implementing the procedural provisions of the National Environmental Policy Act (NEPA) (40 Code of Federal Regulations [CFR] 1500 to 1508), FHWA regulations implementing NEPA (23 CFR 771.101 to 771.139), and FHWA guidance provided in its Environmental Review Toolkit, 23 United States Code (USC) 139 regarding efficient environmental reviews for project decision-making, and the Hawaii Environmental Policy Act (HEPA) / Hawaii Revised Statutes (HRS) Chapter 343.

The Project's primary purpose is to provide a reliable transportation facility in West Maui and improve Honoapiʻilani Highway's resilience by reducing its vulnerability to coastal hazards. Specifically, the Project is intended to address existing coastal erosion and flooding, as well as future coastal erosion and flooding caused by anticipated sea level rise.

The project route is one of the primary corridors for commuters and tourists traveling between Kahului and Lahaina and has heavy traffic volumes throughout the daytime hours. The posted speed limit is 35 to 55 mph on the existing Honoapiʻilani Highway alignment. The future posted speed on new Honoapiʻilani Highway alignment would be 45 mph. The right-of-way is non-uniform in width and varies throughout the project area. A location map of this area can be found in Figure 2-1.

The purpose of this report is to analyze the potential for adverse traffic noise impacts of the Honoapiʻilani Highway Improvements Project (the Project), provide a comparative assessment of the Build Alternatives, and describe potential noise and vibration impacts of the Project's construction.

A noise study is required for this project because modifying the horizontal or vertical location of an existing highway and adding future capacity to an existing highway meet the definition of a Type I Project (HDOT, 2016). Type I projects require mitigation of noise levels that approach or exceed the FHWA noise abatement criteria if the mitigation is found to be both feasible and reasonable to provide.

Existing land uses located along this portion of the Honoapiʻilani Highway include roadways, commercial businesses, office buildings, residential buildings, mixed-use buildings, schools, parks, health care facilities, trails, places of worship, a cemetery, and other uses.

Ten short-term (15-minute) measurements were taken at noise sensitive locations along the proposed alignment along with three 24-hour noise measurements to analyze worst-hour noise levels. Fifty-nine noise receivers were modeled to predict existing and future conditions noise levels.

The FHWA Traffic Noise Model (TNM) was used to model the noise levels at 60 sites for existing conditions and future project conditions along the Honoapiʻilani Highway in the project area. Traffic data used for Existing and Future Year 2045 noise predictions were representative of the PM peak hour, which represents the loudest hour of operation for the highway (i.e. the most vehicles operating



## Executive Summary

at the posted speed limit). The 60 modeled sites represent 44 residences, 10 parks, five parks or recreation areas, one church, one cemetery, three areas of cultural interest, and outdoor areas at eight commercial businesses.

Existing worst-hour traffic noise levels for residential areas range from 35 dBA to 69 dBA depending on the proximity of the receiver to the roadway traffic and the presence of buildings and topography providing noise attenuation between the receiver and the roadway. The worst-hour traffic noise levels do not approach or exceed the NAC at any of the modeled sites.

Future 2045 modeled worst-hour traffic noise levels for the four Build Alternatives are largely the same, with the highest noise levels of 62 dBA predicted at one commercial site, Maui Paintball located in Olowalu. Build Alternative 4 has the highest increase in noise levels over existing noise levels (15 dBA at the Olowalu Petroglyphs) and one impact (substantial increase at the Olowalu Petroglyphs). All four Build Alternatives would not result in any NAC impacts and all alternatives would lower the highest traffic noise levels by 8 dBA to 12 dBA as compared to existing conditions.

One noise barrier was evaluated to reduce traffic noise levels at the one site where noise impacts were predicted with the Project (Build Alternative 4). The evaluated noise barrier was able to achieve the necessary noise reduction to satisfy HDOT Feasibility Criteria; however, the maximum allowance for the evaluated noise barrier that met feasibility was below the planning level cost estimate and will not be considered for placement as part of the Project.

A copy of this final report will be made available to local jurisdictions by HDOT. This report will serve to inform the local planning department of the effects of the highway and highway-construction related noise in the area studied. The information contained within this report can assist local officials in their planning process.

At the time of this report, several undeveloped or vacant lots were located near the proposed project improvements. According to HDOT traffic noise policy, if building permits have been submitted for undeveloped properties, the proposed development needs to be included in the noise study. A review of County of Maui's permitted land use was conducted online in March 2023. The review identified no permits or approvals on file within available online files.

## Chapter 1 INTRODUCTION

The purpose of this report is to analyze the traffic noise impacts of the proposed Honoapiʻilani Highway Improvements Project, Ukumehame to Launiopoko, on the island of Maui (Figure 2-1 Project Location, Figure 2-2, Build Alternatives). The HDOT and the FHWA are evaluating four building alternatives along with a no build alternative to replace the existing two-lane highway alignment. While construction of the Project would accommodate a two-lane highway (one travel lane in each direction), the Build Alternatives have been considered based on a right-of-way width that is sufficient to accommodate a four-lane highway (two travel lanes in each direction) if the need arises and funding becomes available. All Build Alternatives would have a general right-of-way width of approximately 140 feet with additional area required for new intersections and for stormwater management infrastructure.

This study was prepared in accordance with FHWA rules and procedures (FHWA, 1995) and the State of HDOT Highway Noise Policy and Abatement Guidelines (HDOT, 2016). Report elements include:

1. Measurements of existing noise levels at representative noise sensitive receivers;
2. Prediction of future traffic noise levels;
3. Comparison of existing and predicted future traffic noise levels with the FHWA/HDOT Noise Abatement Criteria (NAC);
4. Recommendations to reduce noise impacts;
5. Evaluation of possible noise barriers; and

The effects of construction noise and proposed mitigation measures



## Chapter 2 PROJECT DESCRIPTION

The State of Hawaiʻi Department of Transportation (HDOT) and the Federal Highway Administration (FHWA) are evaluating the Honoapiʻilani Highway Improvements Project (the “Project”) to replace Honoapiʻilani Highway from Ukumehame to Launiopoko, on the island of Maui. While construction of the Project would accommodate a two-lane highway (one travel lane in each direction), the Build Alternatives have been considered based on a right-of-way width that is sufficient to accommodate a four-lane highway (two travel lanes in each direction) if the need arises and funding becomes available. All Build Alternatives would have a general right-of-way width of approximately 140 feet with additional area required for new intersections and for stormwater management infrastructure. The project location is shown on Figure 2-1.

The Build Alternatives’ alignments are largely drawn from the County of Maui’s Pali to Puamana Parkway Plan (2005) with refinements that include changes reflecting early scoping and public outreach completed prior to the NOI / EISPN and Scoping Report in 2022 and 2023, respectively. The Build Alternatives are shown on Figure 2-2.

All the Build Alternatives are based on the existing Honoapiʻilani Highway turning into remaining as a local road under the jurisdiction of Maui County. The road would continue to provide access to public parks and beaches along the coast as well as residences, businesses, and cultural resources in the project area. In the future, with much of the existing roadway located makai of the SLR-XA coastal erosion line, and given the focus on nature-based solutions and avoidance of new shoreline hardening, the existing road may no longer be continuous from Lāhainā Bypass to Pāpalaua Wayside Beach. In addition, the existing roadway would not be directly connected at the merge points of the new alignment with Lāhainā Bypass to the north or the Pali connection to the south. A No Build Alternative is included in the analysis.

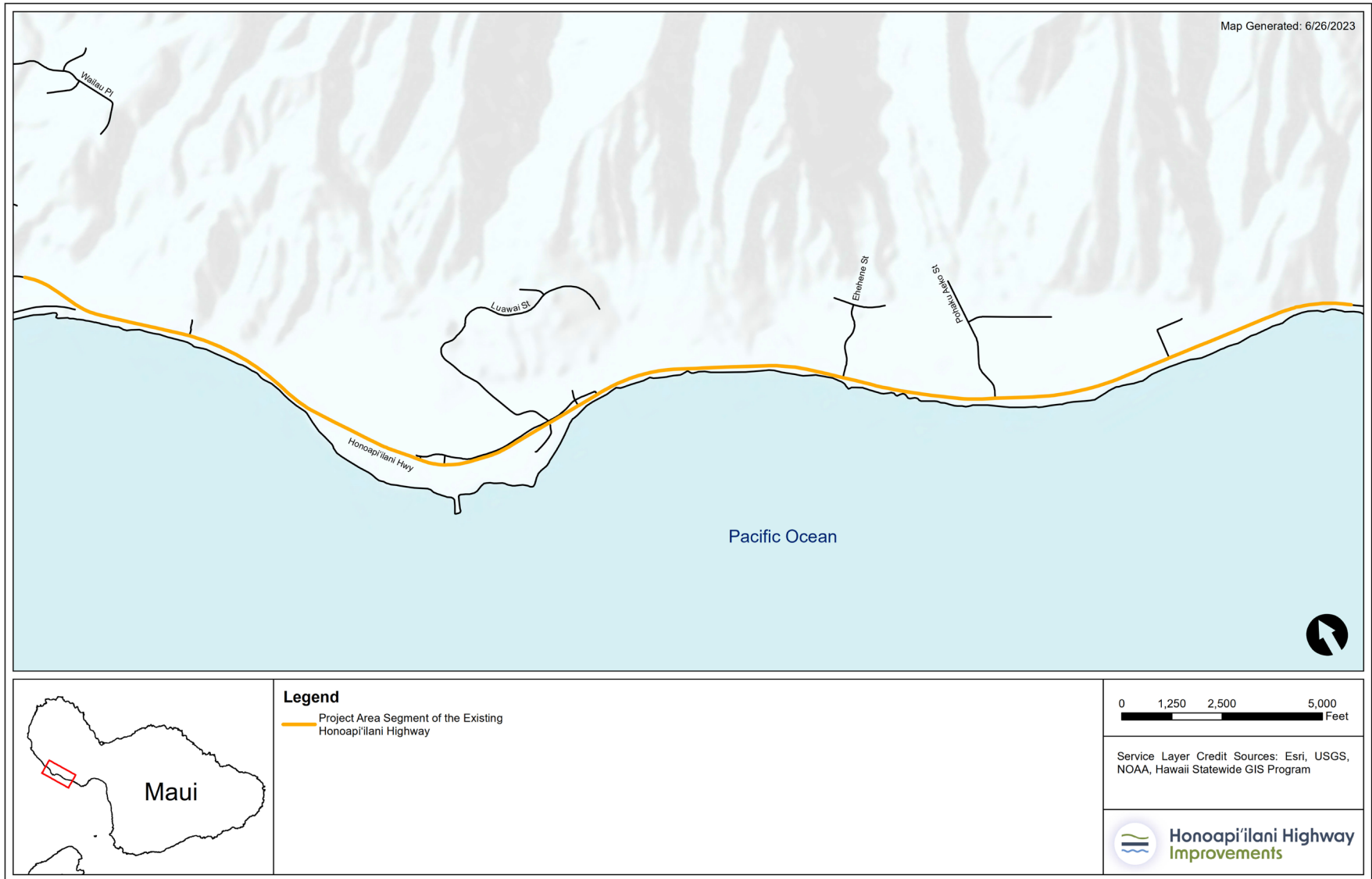
The Project’s primary purpose is to provide a reliable transportation facility in West Maui and improve Honoapiʻilani Highway’s resilience by reducing its vulnerability to coastal hazards. Specifically, the Project is intended to address existing coastal erosion and flooding, as well as future coastal erosion and flooding caused by anticipated sea level rise.

The project route is one of the primary corridors for commuters and tourists traveling between Kahului and Lahaina and has heavy traffic volumes throughout the daytime hours. The posted speed limit is 35 to 55 mph on the existing Honoapiʻilani Highway alignment. The future posted speed on new Honoapiʻilani Highway alignment would be 45 mph. The right-of-way is non-uniform in width and varies throughout the project area.

A noise study is required for this project because modifying the horizontal or vertical location of an existing highway and adding future capacity to an existing highway meet the definition of a Type I Project (HDOT, 2016). Type I projects require mitigation of noise levels that approach or exceed the FHWA noise abatement criteria if the mitigation is found to be both feasible and reasonable to provide.



FIGURE 2-1. Project Location

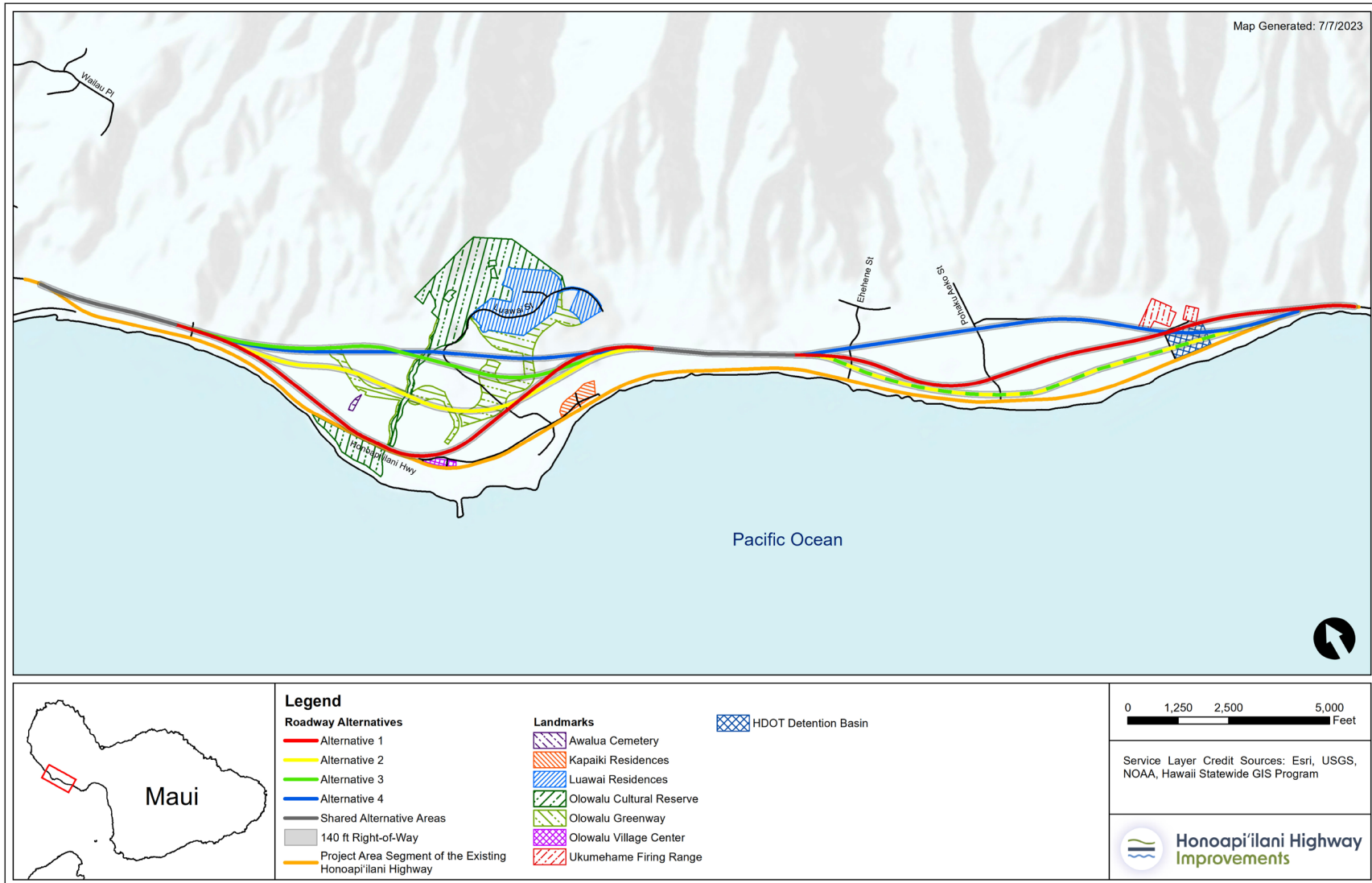


Source: WSP, 2023





FIGURE 2-2. Build Alternatives



Source: WSP, 2023



## Chapter 3 EXISTING NOISE ENVIRONMENT

### 3.1 THE STATE OF HAWAI'I DEPARTMENT OF TRANSPORTATION (HDOT) AND THE FEDERAL HIGHWAY ADMINISTRATION REGULATORY CONTEXT

The Project is a federally funded project and is defined as a Type I noise project under the criteria identified by Title 23 Code of Federal Regulations Part 772, Procedures for Abatement of Highway Traffic Noise and Construction Noise, as well as the HDOT Highway Noise Policy and Abatement Guidelines.<sup>1</sup> A Type I project is “a proposed Federal or Federal-aid highway project for the construction of a highway on new location or the physical alternation of an existing highway which significantly changes the horizontal or vertical alignment or increases the number of through-traffic lanes.”

The FHWA and HDOT have established the following noise analysis procedures for federally funded projects to provide guidance and criteria for noise studies and noise abatement measures:

- Measurement of existing noise levels at representative noise-sensitive receivers
- Prediction of future traffic noise levels
- Comparison of existing and predicted future traffic noise levels with the FHWA/HDOT NAC
- Recommendations to reduce noise impacts
- Evaluation of possible noise barriers
- The effects of construction noise and proposed mitigation measures

Vibration is a periodic motion or oscillation around an equilibrium position that is most notable during construction of a highway project. Vibration can result in the noticeable movement of building floors, rattling of windows, shaking of items on shelves or hanging on walls, and even rumbling sounds. Vehicular roadways do not result in vibration levels that are perceptible or result in architectural or structural damage. As such, an assessment of vibrations from the highway and bridge operations for the Project was not warranted. However, sensitive receptor locations near construction-related activities have the potential for exposure to high vibration levels. Chapter 5 of this report includes further discussion of potential construction-related impacts.

### 3.2 METHODOLOGY

This section outlines the approach that was used to collect and evaluate the beneficial and adverse effects of the Build Alternatives related to noise and vibration. It includes an introduction to acoustics, a description of the study area, relevant laws and regulations, and methods for collecting data, assessing impacts, and evaluating possible mitigation measures.

---

<sup>1</sup> State of Hawaii Department of Transportation (HDOT). 2016. Highway Noise Policy and Abatement Guidelines. April 2016.



### 3.2.1 Noise Fundamentals

Noise, or sound, is any change in air pressure the human ear can detect, from barely perceptible to levels that can cause hearing damage. In the human ear, these changes in air pressure are translated to sound. The greater the change in air pressure, the louder the sound. For example, a quiet whisper in the library creates a relatively small change in the room air pressure, whereas air pressure changes are much greater in the front row of a rock concert. This section discusses how noise is evaluated (i.e., its definition, transmission characteristics, and measurement) and provides typical noise levels for reference.

#### 3.2.1.1 Decibel Scale

Sound is measured in terms of both loudness and frequency. The unit used to measure the loudness of sound is called a decibel (dB). The dB scale is a logarithmic conversion of air pressure level variations (measured in a unit called a pascal) to a unit of measure with a more convenient numbering system. The adjusted dB scale, referred to as the A-weighted dB (dBA) scale, provides an accurate “single number” measure of what the human ear can hear. This analysis uses dBA as the unit of measure.

#### 3.2.1.2 Typical Noise Levels

In most neighborhoods, nighttime noise levels are noticeably lower than daytime levels. In a quiet rural area at night, noise levels from crickets or wind rustling leaves on the trees can range between 32 and 35 dBA. As residents start their days and local traffic increases, the same rural area can have noise levels ranging from 50 to 60 dBA. Noise levels in urban neighborhoods are louder than those in rural areas. Noise levels during the day in a noisy urban area are frequently as high as 70 to 80 dBA. Nighttime noise levels in urban areas are generally much quieter than daytime noise levels and can range from 40 to 50 dBA.<sup>2</sup>

Long-term, or continuous, exposure to very loud noises can damage the human ear. Noise levels exceeding 85 dBA over continuous periods can result in permanent hearing loss. Noise levels above 110 dBA become first intolerable, then extremely painful. **FIGURE 3-1** shows noise levels for typical transportation sources, followed by a description of a normal human response to each.

---

<sup>2</sup> Federal Transit Administration. 2018. Transit Noise and Vibration Impact Assessment Manual. FTA Report Number 0123. September 2018

FIGURE 3-1. Typical Noise Levels

NOISE SOURCE OR ACTIVITY		SUBJECTIVE IMPRESSION	RELATIVE LOUDNESS (human judgment of different sound levels)
Jet aircraft takeoff from carrier (50 feet)	140	Threshold of pain	64 times as loud
50-horsepower siren (100 feet)	130		32 times as loud
Loud rock concert near stage Jet takeoff (200 feet)	120	Uncomfortably loud	16 times as loud
Float plane takeoff (100 feet)	110		8 times as loud
Jet takeoff (2,000 feet)	100	Very loud	4 times as loud
Heavy truck or motorcycle (25 feet)*	90		2 times as loud
<b>Garbage disposal (2 feet)</b> <b>Pneumatic drill (50 feet)</b>	80	<b>Moderately loud</b>	<b>Reference loudness</b>
Vacuum cleaner (10 feet)	70		1/2 as loud
Passenger car at 65 mph (25 feet)*	60		1/4 as loud
Typical office environment	60		1/4 as loud
Light auto traffic (100 feet)*	50	Quiet	1/8 as loud
Bedroom or quiet living room Bird calls	40		1/16 as loud
Quiet library, soft whisper (15 feet)	30	Very quiet	
High quality recording studio	20		
Acoustic test chamber	10	Just audible	
	0	Threshold of hearing	

Source:

Beranek, L.L., 1988. *Noise and Vibration Control*. Institute of Noise Control Engineering. McGraw Hill (1988) and U.S. Environmental Protection Agency (EPA), 1974. *Information on Levels of Environmental Noise Requisite to Protect Public Health and Welfare with an Adequate Margin of Safety*. Report Number 550/9-74-004.

Public response to noise depends greatly on the range over which the noise varies in an environment. For example, people generally find a moderately high, constant noise level more tolerable than a quiet background level interrupted by high-level noise intrusions. Considering this subjective response, it is often useful to look at a statistical distribution of noise levels over a given time period. Such distributions identify the noise level exceeded and the percentage of time exceeded, allowing a more complete description of the range of noise levels during the given measurement period.

TABLE 3-1 summarizes changes in noise levels that a human can perceive. Generally, the average human is unable to perceive noise level changes until the changes measure in the 2 to 3 dBA range, but these increases are barely perceptible to most listeners, and it is not until the noise level change reaches 5 dBA or more that most humans can readily perceive changes in noise levels.



TABLE 3-1. Average Human Ability to Perceive Changes in Noise Levels

NOISE LEVEL CHANGE (dBA)	HUMAN PERCEPTION
0 to 2	Not perceptible to most listeners
2 to 3	Barely perceptible
5	Readily perceptible
10	Clearly perceptible

Source: Bolt Beranek and Newman, Inc. June 1973. Fundamentals and Abatement of Highway Traffic Noise, Report No. PB-222-703. Prepared for FHWA

Noise levels from most sources tend to vary with time. For example, noise levels increase when a car approaches, then reach a maximum peak as it passes, and decrease as the car moves farther away. In this example, noise levels within a 1-minute timeframe may range from 45 dBA as the vehicle approaches to 65 dBA as it passes and return to 45 dBA as it moves farther away. To account for the variance in loudness over time, the equivalent sound level ( $L_{eq}$ ) is used. The  $L_{eq}$  is defined as the energy average noise level, in dBA, for a specific time period (for example, 1 minute). Returning to the example of the passing car, the energy average noise level is assumed to be 60 dBA during the entire time the car is heard as it passes by. In this example, the noise level is stated as 60 dBA  $L_{eq}$ . The same approach is used to determine the  $L_{eq}$  for other time periods such as hourly ( $L_{eq}$  [h]) or over a 24-hour period ( $L_{eq}$  [24h]).

### 3.2.1.3 Noise Propagation

Several factors determine how sound levels decrease, or attenuate, over a distance. Two general categories apply to noise sources: 1) a point source (e.g., a church bell) and 2) a line source (e.g., constant flowing traffic on a busy highway).

A single-point noise source will attenuate at a rate of 6 dB each time the distance from the source doubles. Thus, a point source producing a noise level of 60 dB at 50 feet attenuates to 54 dB at 100 feet and to 48 dB at 200 feet. A line source such as a highway, however, generally reduces at a rate of approximately 3 dB each time the distance doubles. Using the example above, a line source measured at 60 dB at 50 feet would attenuate to 57 dB at 100 feet and to 54 dB at 200 feet.

The physical surroundings between the source and the receiver influence the attenuation of point and line sources. For example, interactions of sound waves with the ground often result in slightly higher attenuation (called ground absorption effects) than the reduction factors given in the preceding paragraph. Other factors affecting the attenuation of sound with distance include existing structures, topography, dense foliage, ground cover, and atmospheric conditions (e.g., wind, temperature, and relative humidity).

### 3.2.1.4 Noise Criteria

The HDOT Noise Policy and Abatement Guidelines policy implements FHWA regulations on noise abatement. The FHWA has established NAC for different exterior and interior land use activities (TABLE 3-2). The NAC do not constitute legally enforceable noise standards, but represent a yardstick for evaluating the effect of project noise on the surrounding community. The State of Hawaiʻi has adopted the NAC as its standard.

TABLE 3-2. Noise Abatement Criteria

ACTIVITY CATEGORY	ACTIVITY Leq(h) dBA <sup>1</sup>	CRITERIA L <sub>10</sub> (h) dBA <sup>2</sup>	EVALUATION LOCATION	DESCRIPTION OF ACTIVITY
A	57	60	Exterior	Lands on which serenity and quiet are of extraordinary significance and serve an important public need and where the preservation of those qualities is essential if the area is to continue to serve its intended purpose.
B <sup>3</sup>	67	70	Exterior	Residential.
C <sup>3</sup>	67	70	Exterior	Active sports areas, amphitheatres, auditoriums, campgrounds, cemeteries, day care centers, hospitals, libraries, medical facilities, parks, picnic areas, places of worship, playgrounds, public meeting rooms, public or nonprofit institutional structures, radio studios, recording studios, recreation areas, Section 4(f) sites, schools, television studios, trails, and trail crossings.
D	52	55	Interior	Auditoriums, day care centers, hospitals, libraries, medical facilities, places of worship, public meeting rooms, public or nonprofit institutional structures, radio studios, recording studios, schools, and television studios.
E <sup>3</sup>	72	75	Exterior	Hotels, motels, offices, restaurants/bars, and other developed lands, properties or activities not included in A-D or F.
F	---	---	---	Agriculture, airports, bus yards, emergency services, industrial, logging, maintenance facilities, manufacturing, mining, rail yards, retail facilities, shipyards, utilities, (water resources, water treatment, electrical), and warehousing.
G	---	---	---	Undeveloped lands that are not permitted.

Source: U.S. Department of Transportation, Federal Highway Administration. 2010. Highway Traffic Noise: Analysis and Abatement. Revised December 2010.

Notes: L<sub>10</sub>(h) is the noise level exceeded for 10% of the time of the measurement duration (1 hour).

- <sup>1</sup> Either Leq(h) or L<sub>10</sub>(h) (but not both) may be used on a project.
- <sup>2</sup> The Leq(h) and the L<sub>10</sub>(h) Activity Criteria values are for impact determination only and are not design standards for noise abatement measures.
- <sup>3</sup> Includes undeveloped lands permitted for this activity category.

Under HDOT noise policy, a noise impact occurs when the predicted traffic noise levels approach or exceed the NAC, or when the predicted traffic noise levels substantially exceed the existing noise levels. “Approach” means within 1 dBA less than the NAC, and “substantially exceed the existing noise levels” means an increase of at least 15 dBA. If the NAC are approached or exceeded, or if there is a substantial increase above the existing noise level, noise abatement measures must be considered.



### **3.2.2 Study Area**

The noise study area for the Project includes the full project area of approximately 6 miles in length and encompasses the Build Alternatives described in Chapter 2 of this report. As defined in HDOT's noise policy, the Project's noise study area is large enough to include all sensitive receptors identified in the evaluation, which extends beyond an area comprising a 500-foot-wide swath centered along the highway centerline (or the centerline of each Build Alternative). This area is delineated as the noise-sensitive region for traffic noise modeling. However, because the closest sensitive receptor is likely to be farther away than this delineation, particularly in evaluating the Build Alternatives, the actual distance to the closest appropriate location is described in this Draft Environmental Impact Statement (EIS). Figure 3-2 and Figure 3-3 shown project area zoning and Figure 3-4 and Figure 3-5 show existing land use.

### **3.2.3 Data Collection Methods**

As part of the noise abatement analyses, sound level measurements were recorded to validate the FHWA Traffic Noise Model (TNM), version 2.5. These sound level measurements were not used to establish the existing noise levels in the study area. Once the model was validated with the sound measurement data, the existing sound levels were established by modeling the worst noise hour traffic volumes. Worst-hour or loudest hour traffic from 2023 was used to model existing conditions, and year 2045 traffic was used to model No Build Alternative and Build Alternatives conditions. The following sections describe the methods and equipment used to collect the noise data.

#### **3.2.3.1 Noise Monitoring**

HDOT performed noise monitoring from June 20 to June 23, 2023, at 13 outdoor locations within the study area (Figure 3-6). Of the 13 monitoring sites, three were 24-hour measurements and the other 10 were short-term (15 to 30 minutes). HDOT conducted the 24-hour site measurements to document the peak or loudest hour occurring over a 24-hour period at residential and land use activities where sleep occurs. The short-term sites were used primarily for traffic noise and land uses with daytime activities such as residences, parks, and places of worship. Site observations indicated and the noise levels from the three 24-hour sites confirmed that short-term measurement periods provided sufficient traffic noise levels with free-flow traffic conditions for noise model validation and prediction of worst-hour or loudest hour traffic noise levels. Appendix A provides field measurement data and site photographs of the short-term monitoring sites. Appendix B provides hourly noise levels collected at the three 24-hour measurement locations.

HDOT took the noise measurements in accordance with the American National Standard Institute (ANSI) procedures for community noise measurements and the FHWA Noise Measurement Field Guide.<sup>3</sup> The measurement locations were placed at least 5 feet from any solid structure to prevent acoustical reflections and at a height of 5 feet off the ground. The equipment HDOT used for noise monitoring included Larson Davis Type 720 and 820 sound level meters, which were calibrated before and after the measurement period using handheld or software-based equipment calibration. Odin Metrology, Inc. performs a complete system calibration annually with the measurement systems

---

<sup>3</sup> Federal Highway Administration. 2017. Noise Measurement Field Guide – Final Report. FHWA-HEP-18-066.

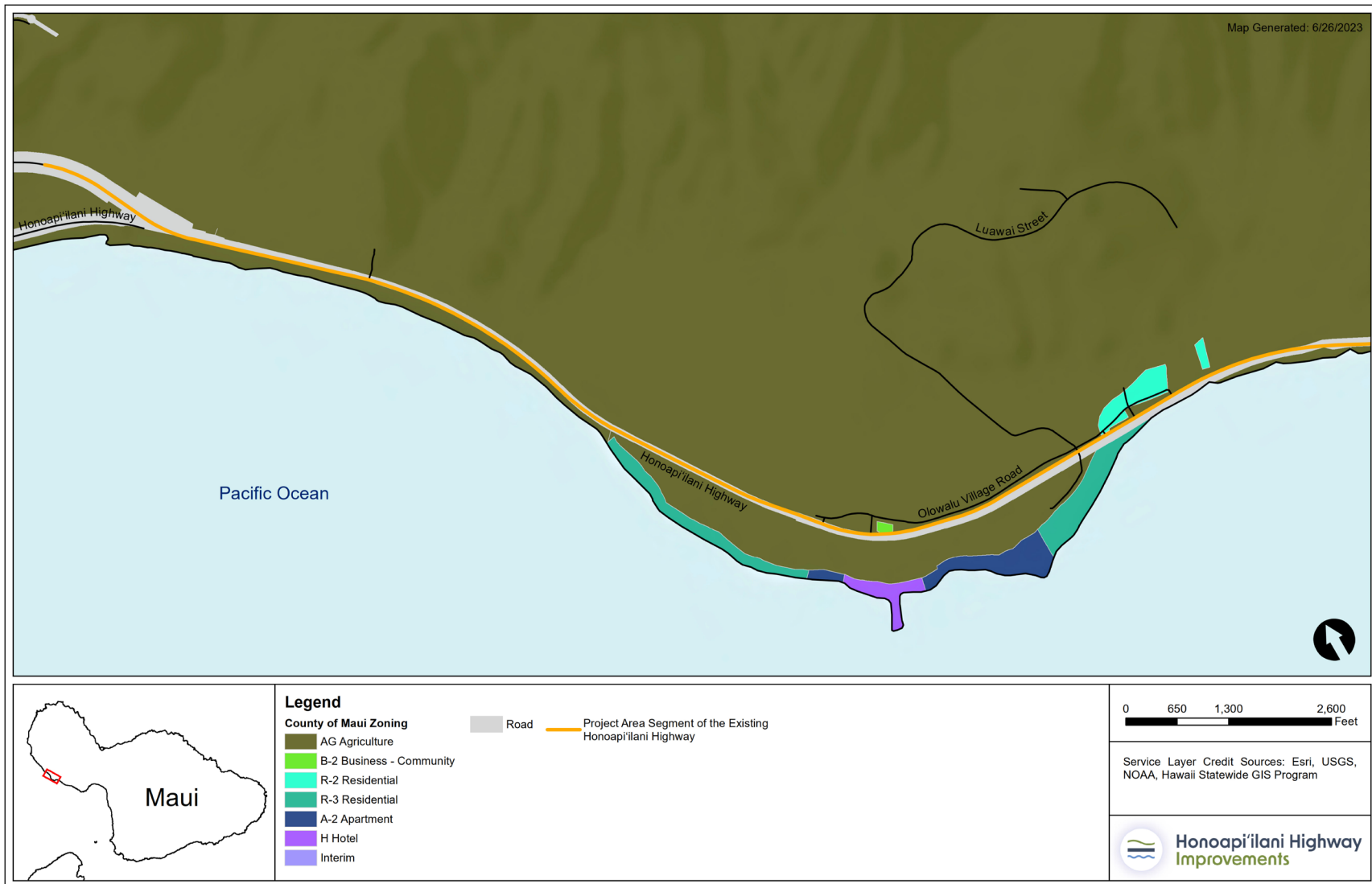


meeting or exceeding the requirements for an ANSI Type I noise measurement system. Appendix C provides laboratory calibration certificates for all field instrumentation used to conduct monitoring.



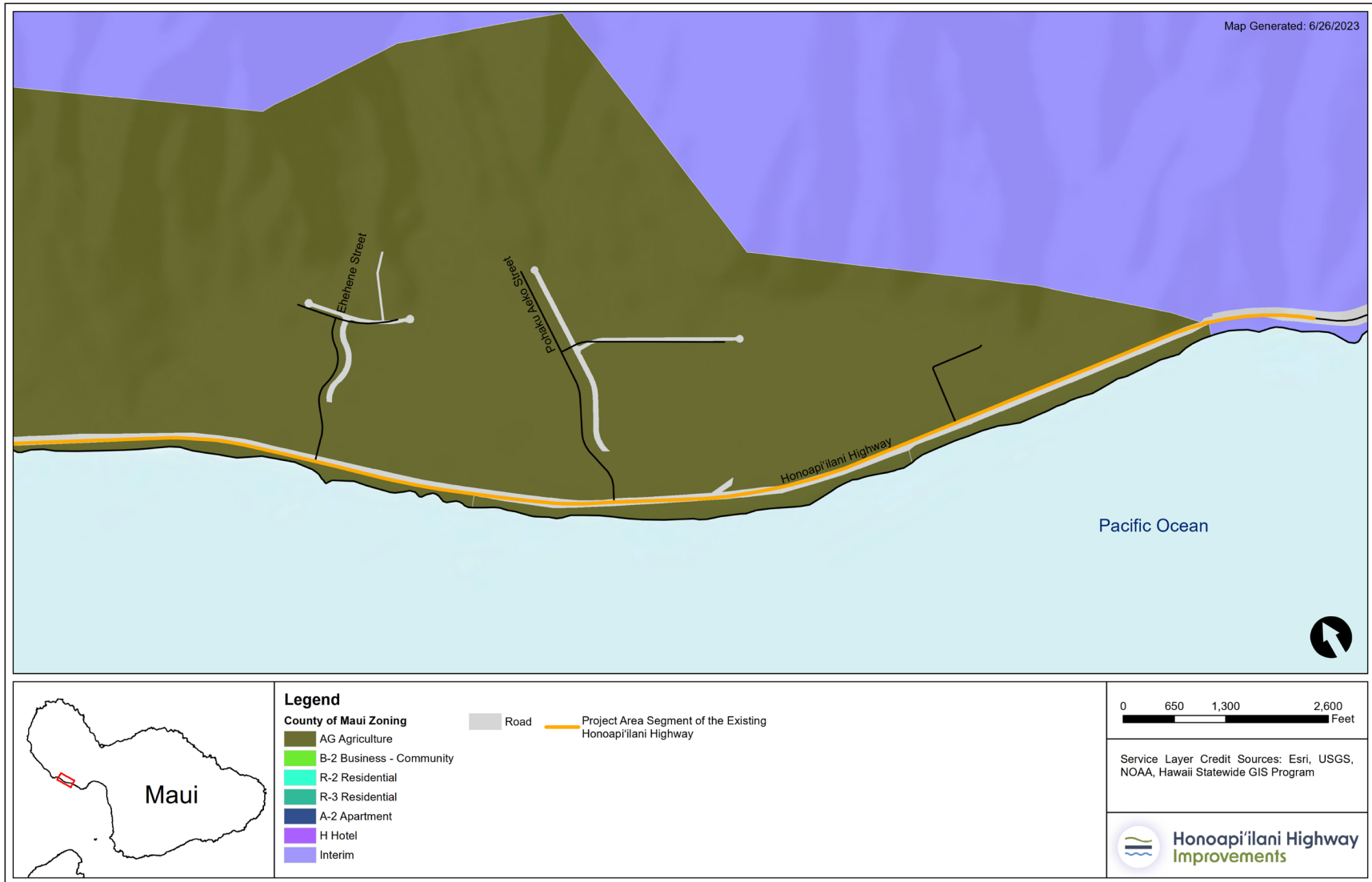


FIGURE 3-2. Project Area Zoning, Olowalu



Source: WSP, 2023

FIGURE 3-3. Project Area Zoning, Ukumehame



Source: WSP, 2023



FIGURE 3-4. Project Area Land Use, Olowalu



Source: WSP, 2023

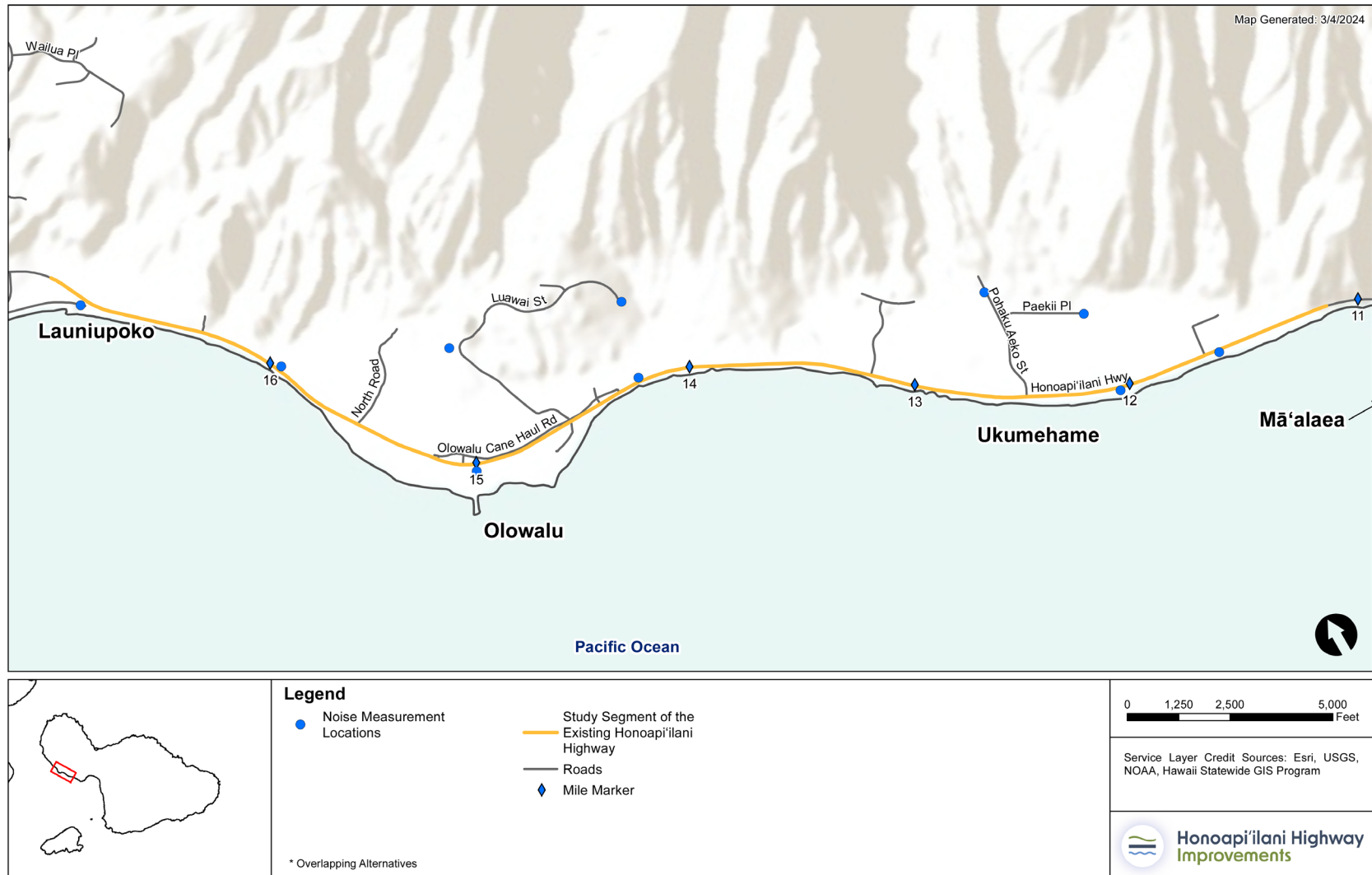
FIGURE 3-5. Project Area Land Use, Ukumehame



Source: WSP, 2023



FIGURE 3-6. Noise Monitoring Locations



Source: WSP, 2023

HDOT performed the noise measurements during satisfactory weather conditions and during times when traffic on Honoapiʻilani Highway was free flowing. The temperatures on these days ranged from 73 to 88 degrees Fahrenheit with mostly sunny skies, no precipitation, and low wind speeds during measurement periods.

HDOT simultaneously counted traffic volumes for the measurement sites. The traffic counts used five vehicle classifications: automobiles, medium trucks, heavy trucks, motorcycles, and buses. HDOT observed the vehicle speeds during the measurements, and the corridor was driven daily to estimate vehicle speeds during measurement periods. Noise measurements were not taken unless traffic conditions were free flowing. HDOT performed traffic counts at 15-minute intervals along Honoapiʻilani Highway from vantage points with direct line-of-sight to traffic. Local traffic was also counted when observed along with notes on observed sound sources not from vehicular traffic.

Noise measurement locations are provided on Figure 3-6 with measured noise level data provided in Table 3-3 and Appendix A.

### ***3.2.3.2 Traffic Noise Model Validation***

HDOT used the FHWA (TNM) version 2.5, to model existing traffic noise levels at the measurement sites along the existing lane configuration of Honoapiʻilani Highway and the sites along the Build Alternatives. The model estimates the traffic noise level at a receptor location resulting from a series of straight-line roadway segments. Noise emissions from free-flowing traffic depend on the following:

- Number of automobiles, medium trucks, and heavy trucks per hour
- Vehicular speed
- Reference noise emission levels of specified vehicles

The TNM also considers effects of intervening barriers, topography, trees, and atmospheric absorption. By intent and design, HDOT did not include noise from sources other than traffic; therefore, when non-traffic noise (e.g., aircraft) was considerable in an area, the TNM results were less than the measured noise levels.

HDOT exported base maps as DXF files and imported them into the TNM. In addition, ArcGIS was used to develop the TNM, with major roadways, retaining walls, topographical features, building rows, and sensitive receptors being digitized into the model. The United States Geological Survey 7.5-minute Digital Elevation Model was also used.<sup>4</sup>

HDOT imported the Project's design files into ESRI ArcMap® GIS software to develop geometry for TNM elements such as roadways, receivers, terrain lines, and ground zones. The elevation data was based on existing survey data and roadway design files were developed. HDOT then imported the geometry into the TNM to develop a traffic noise model for existing conditions.

HDOT scaled up traffic volumes counted during the short-term measurement periods to 1-hour volumes and entered the traffic volumes into the TNM along with the measured vehicle speeds to

---

<sup>4</sup> U.S. Geological Survey (USGS). <https://viewer.nationalmap.gov/basic/> (accessed June 2023).



**EXISTING NOISE ENVIRONMENT**

validate the TNM. Measured and modeled noise levels for the measured sites near Honoapiʻilani Highway generally agreed (within 3.0 dBA). TABLE 3-3 compares measured noise levels and levels modeled in the TNM for the measured sites.

**TABLE 3-3. Noise Measurement Data and Traffic Noise Model Validation**

SITE ID	SITE LOCATION	LAND USE	DATE OF MEASUREMENT/ START TIME	MEASURED NOISE LEVEL	MODELED NOISE LEVEL	DIFFERENCE BETWEEN MEASURED - MODELED
ST-1	Luawai Street, east terminus	Adjacent to Residence	6/20/2023/ 11:30	45	N/A	N/A
ST-2	Utility Building near Petroglyphs	Utility Building near Petroglyphs	6/20/2023/ 12:10	47	N/A	N/A
ST-3	Pāpalaua Wayside Park	Park	6/20/2023/ 14:30	71	69	-2
ST-4	Adjacent to Residence on Pāhaku 'Aeko Street	Adjacent to Residence	6/20/2023/ 14:55	44	N/A	N/A
ST-5	Adjacent to Olowalu Lanakila Hawaiian Church	Adjacent to Church	6/20/2023/ 15:35	63	64	1
ST-6	Paeki'i Place, east terminus	Adjacent to Residence	6/21/2023/ 11:50	47	N/A	N/A
ST-7	Ukumehame Beach Park	Park	6/21/2023/ 12:55	66	67	1
ST-8	Southern terminus of former Honoapiʻilani Highway	Adjacent to Beach	6/21/2023/ 15:25	58	60	2
ST-9	Olowalu Landing Parking	Adjacent to Park	6/21/2023/ 15:55	60	60	0
ST-10	Honoapiʻilani Highway frontage, south of Recycling Center	Adjacent to access road	6/21/2023/ 16:35	63	63	0

Source: WSP, 2023.

N/A 30-minute noise measurements were conducted at sites ST-1, ST-2, ST-4, and ST-6 as a sample of existing ambient conditions. Measured noise levels at these sites were not validated within TNM due to the distance from the existing Honoapiʻilani Highway alignment over 1,500 feet from each site where roadway noise was not audible at the time of the noise measurement.

Traffic data used for existing year 2023 and future year 2045 noise predictions were the PM peak hour provided by the traffic analysis performed for the Project. Modeled traffic volumes are included in the Appendix D of this report. Modeled volumes included the following vehicle percentages: 1.0% heavy trucks or vehicles with more than three axles, 2.5% medium trucks or three-axle vehicles, and 96.5% automobiles or two-axle vehicles. The vehicle mix is based on modeled vehicle classifications and traffic information provided by HDOT and the Honoapiʻilani Highway Draft EIS's traffic data collection.



### 3.2.3.3 Results of Existing Noise Measurements

TABLE 3-3 presents the measured noise levels at each of the 10 short-term measurement locations. Existing measured levels ranged from 44 dBA to 71 dBA depending on the proximity of the measurement to the existing Honoapi'ilani Highway alignment. The primary noise source at measurement locations located within a few hundred feet of Honoapi'ilani Highway was traffic noise from Honoapi'ilani Highway. At receptor sites ST-1, ST-2, ST-4, and ST-6, 30-minute noise measurements were conducted to document a sample of ambient conditions at these locations over 1,500 feet from Honoapi'ilani Highway, where roadway noise was not audible at the time of the noise measurement.

### 3.2.4 Existing and Future Noise-Sensitive Land Uses

HDOT identified existing and future noise-sensitive land uses and activities adjacent to Honoapi'ilani Highway and nearby roadways through site inspections and existing mapping. Existing land uses located along this portion of the highway include residential buildings, parks, trails, places of worship, a cemetery, cultural resource areas, and other uses. The residences along the study area are Category B, and the recreation areas, parks, places of worship, and similar uses are Category C. Category B and Category C activities have an exterior NAC of  $L_{eq}(h)$  of 67 dBA. Category E commercial businesses in the area have an exterior NAC of  $L_{eq}(h)$  of 72 dBA.

During site observations, HDOT identified areas of undeveloped land within the study area that could be part of a future development. HDOT reviewed Maui's Automated Planning and Permitting System online permitting files in April 2023 for any permitted development located within 500 feet of the centerline of the project alternative alignments.<sup>5</sup> At the time of this Draft EIS, no permits are on file at the City and County of Honolulu Department of Planning and Permitting for planned developments along the study area.

#### 3.2.4.1 Existing Conditions

HDOT included 60 modeled sites in the TNM to describe noise levels at noise-sensitive land uses located along the study area. The 59 modeled sites represent 44 residences, 10 parks, five parks or recreation areas, one church, one cemetery, three areas of cultural interest, and outdoor areas at eight commercial businesses. Figure 3-6 shows the approximate locations of the modeled sites.

TABLE 3-4 presents the modeled existing worst-hour traffic noise levels, the number of receptors represented by each measurement site, and the NAC for each of the short-term and modeled measurement locations. Worst-hour traffic noise levels for residential areas range from 35 dBA to 69 dBA depending on the proximity of the receiver to the roadway traffic and the presence of buildings and topography providing noise attenuation between the receiver and the roadway. The worst-hour traffic noise levels do not approach or exceed the NAC at any of the modeled sites.

---

<sup>5</sup> [https://mapps.co.maui.hi.us/energov\\_prod/selfservice/MauiCountyHIProd#/search](https://mapps.co.maui.hi.us/energov_prod/selfservice/MauiCountyHIProd#/search)





**EXISTING NOISE ENVIRONMENT**

**TABLE 3-4. Predicted Existing Worst-Hour Traffic Noise Levels**

SITE ID	DESCRIPTION OF RECEIVERS REPRESENTED	NUMBER OF RECEIVERS REPRESENTED	HDOT NOISE ABATEMENT CATEGORY (CRITERION*)	MODELED EXISTING 2023 WORST-HOUR LEQ(H), DBA	IMPACT TYPE* (S, A/E, OR NONE)
M1	Pāpalaua Wayside Park	1	C/66	60	None
M2	Ukumehame Beach Park	1	C/66	62	None
M3	Ukumehame Firing Range	1	E/71	46	None
M4	Residence at Paeki'i Pl.	1	B/66	41	None
M5	Residence at Pāhaku 'Aeko St.	1	B/66	41	None
M6	Residence/SOD Farm at Ehehene St.	2	B/66, E/71	46	None
M7	Residence at Ehehene St.	1	B/66	44	None
M8	Residence beyond Ehehene St.	1	B/66	39	None
M9	Ukumehame Cultural Reserve	1	C/66	38	None
M10	Olowalu Lanakila Hawaiian Church	1	C/66	56	None
M11	Residence at Olowalu Village Rd.	1	B/66	54	None
M12	Residence at Olowalu Village Rd.	1	B/66	59	None
M13	Residence at Olowalu Village Rd.	1	B/66	58	None
M14	Residence at Olowalu Village Rd.	1	B/66	57	None
M15	Residence at Olowalu Village Rd.	1	B/66	57	None
M16	Residence at Olowalu Village Rd.	1	B/66	57	None
M17	Residence at Olowalu Village Rd.	1	B/66	60	None
M18	Residence at Olowalu Village Rd.	1	B/66	54	None
M19	Residence at Olowalu Village Rd.	1	B/66	55	None
M20	Residence at Olowalu Village Rd.	1	B/66	53	None
M21	Residence at Olowalu Village Rd.	1	B/66	53	None
M22	Residence at Olowalu Village Rd.	1	B/66	60	None
M23	Olowalu Beach	1	C/66	50	None
M24	Camp Olowalu	1	C/66	56	None
M25	Residence at Olowalu Village Rd.	1	B/66	48	None

**EXISTING NOISE ENVIRONMENT**

SITE ID	DESCRIPTION OF RECEIVERS REPRESENTED	NUMBER OF RECEIVERS REPRESENTED	HDOT NOISE ABATEMENT CATEGORY (CRITERION*)	MODELED EXISTING 2023 WORST-HOUR LEQ(H), DBA	IMPACT TYPE* (S, A/E, OR NONE)
M26	Residence at Olowalu Village Rd.	1	B/66	48	None
M27	Residence at Olowalu Village Rd.	1	B/66	49	None
M28	Olowalu Landing	1	C/66	47	None
M29	Commercial – Plantation House	1	E/71	48	None
M30	Residence at Kuahulu Pl.	1	B/66	51	None
M31	Residence at Kuahulu Pl.	1	B/66	49	None
M32	Residence at Kuahulu Pl.	1	B/66	48	None
M33	Commercial – Leoda’s Kitchen and Pie Shop	1	E/71	66	None
M34	Residence/ Commercial – Olowalu General Store	2	B/66, E/71	65	None
M35	Commercial – The Maui Butterfly Farm	1	E/71	65	None
M36	Commercial – Olowalu Juice Stand	1	E/71	69	None
M37	Residence at Luawai St.	1	B/66	41	None
M38	Residence at Luawai St.	1	B/66	43	None
M39	Residence at Luawai St.	1	B/66	43	None
M40	Residence at Luawai St.	1	B/66	43	None
M41	Residence at Luawai St.	1	B/66	42	None
M42	Residence at Luawai St.	1	B/66	43	None
M43	Residence at Luawai St.	1	B/66	43	None
M44	Residence at Luawai St.	1	B/66	42	None
M45	Residence at Luawai St.	1	B/66	41	None
M46	Residence at Kalai Pl.	1	B/66	41	None
M47	Residence at Kalai Pl.	1	B/66	41	None



**EXISTING NOISE ENVIRONMENT**

SITE ID	DESCRIPTION OF RECEIVERS REPRESENTED	NUMBER OF RECEIVERS REPRESENTED	HDOT NOISE ABATEMENT CATEGORY (CRITERION*)	MODELED EXISTING 2023 WORST-HOUR LEQ(H), DBA	IMPACT TYPE* (S, A/E, OR NONE)
M48	Residence at Kalai Pl.	1	B/66	43	None
M49	Residence at Luawai St.	1	B/66	42	None
M50	Residence at Luawai St.	1	B/66	42	None
M51	Residence at Kalai Pl.	1	B/66	41	None
M52	Residence at Kalai Pl.	1	B/66	40	None
M53	Olowalu Cultural Reserve	1	C/66	35	None
M54	Residence at Luawai St.	1	B/66	36	None
M55	Olowalu Petroglyphs	7	C/66	36	None
M56	Residence at Luawai St.	1	B/66	41	None
M57	Residence at Luawai St.	1	B/66	41	None
M58	Awalua Cemetery	1	C/66	46	None
M59	Commercial - Paintball	1	E/71	49	None
M60	Residence at Olowalu Village Rd.	1	B/66	45	None

Source: WSP, 2023.

Note: See Table 16-2 for descriptions of Noise Abatement Categories.

**Bold** = level approaches or exceeds the NAC.

The calculation of dwelling units represented by site M55 were calculated using HDOT’s method of comparing the impact area (estimated at 30,000 square feet) to the typical urban lot size of 4,200 square feet when required to determine noise barrier feasibility and reasonableness.

A “Receiver” is an area of frequent human outdoor activity, homes, apartments, parks, etc.

\*Impact Type: S = Substantial Increase (15 dBA or more), A/E = Approach or Exceed NAC.

## Chapter 4 FUTURE TRAFFIC NOISE LEVELS

The noise analysis considers traffic noise levels at receivers for the future No Build Alternative and four Build Alternatives.

### 4.1 PREDICTION METHODOLOGY

The FHWA TNM was used to model the noise levels in 2045 at 60 modeled sites that represent 44 residences, 10 parks, five parks or recreation areas, one church, one cemetery, three areas of cultural interest, and outdoor areas at eight commercial businesses with and without the proposed project improvements (Project Alternatives 1, 2, 3, and 4) along the proposed new Honoapi'ilani Highway alignments. Input variables to noise modeling and analysis include traffic volumes, vehicle speeds, and vehicle fleet mix (automobile, medium truck, and heavy truck percentages). The noise analysis considers the peak traffic hour as the noisiest hour of the day. The number of vehicles expected to travel on Honoapi'ilani Highway in 2045 is predicted to be greater than existing conditions (2023), but the greatest contribution to traffic noise would remain Honoapi'ilani Highway. Appendix D provides future modeled traffic data. Build Alternative noise levels are shown by receptor location in **FIGURE 4-1** and presented in **TABLE 4-1**.

#### 4.1.1 Noise Impact Analysis

In terms of the one-hour  $L_{eq}(h)$  noise descriptor, a noise impact could potentially require mitigation if either of the following conditions is predicted to occur:

- Future year traffic noise approaches (within 2 dBA) or exceeds the FHWA NAC; or
- Future year traffic noise substantially exceeds (15 dBA or more) the existing ambient noise level.

#### 4.1.2 No Build Alternative

Predicted 2045 traffic noise levels for the No Build Alternative are expected to be within 2 dBA of existing noise levels. An increase of 1 dBA to 2 dBA in future noise levels is predicted at most sites, which is the result of an increase in future traffic. The NAC of 67 dBA  $L_{eq}(h)$  is predicted to be approached or exceeded at one of the 60 modeled sites representing one residence located next to the Olowalu General Store (Table 4-1). Worst-hour future traffic noise levels for the No Build Alternative range from 36 dBA to 70 dBA depending on the proximity of the receiver to Honoapi'ilani Highway.

#### 4.1.3 Build Alternative 1

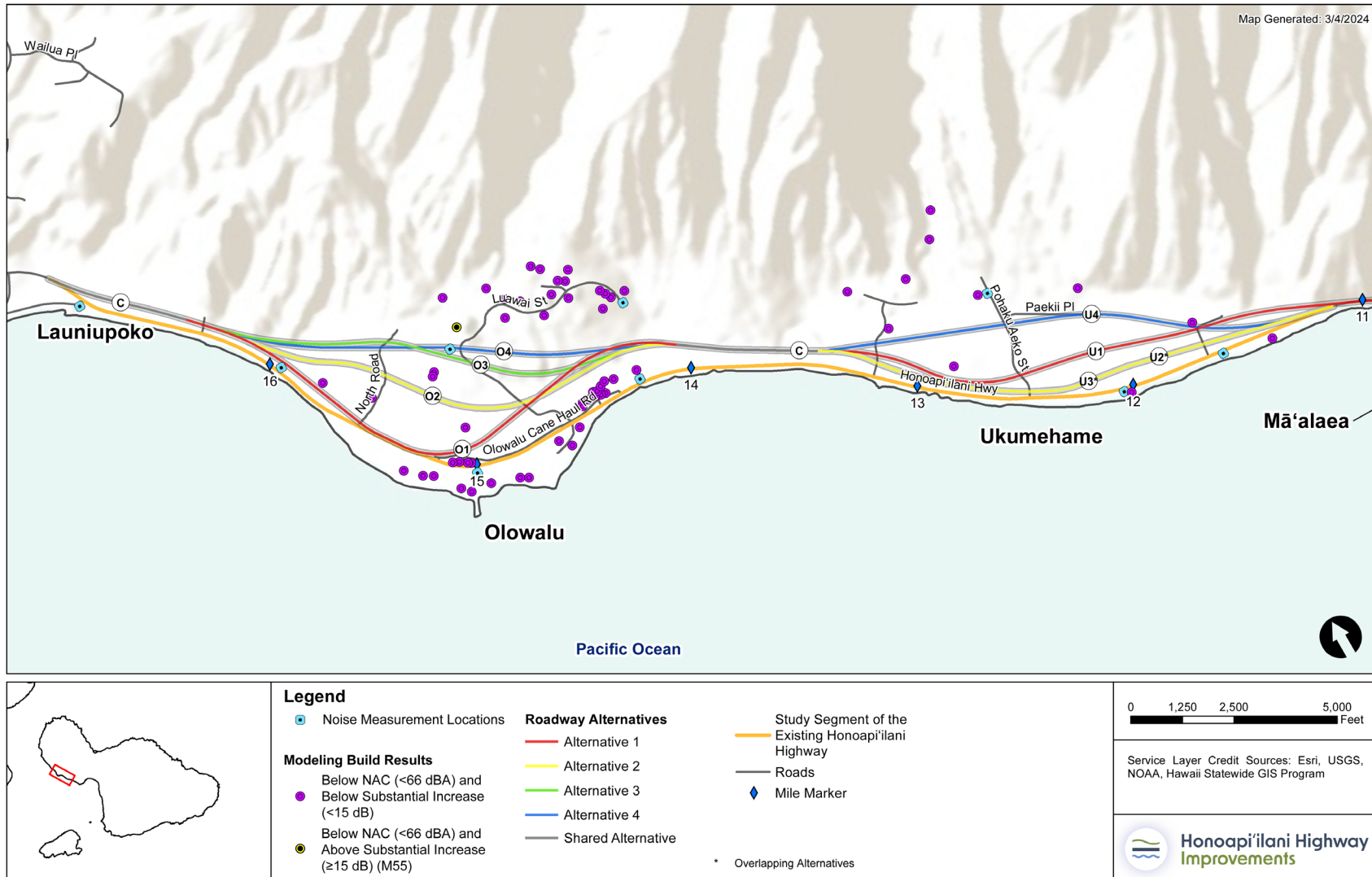
Predicted 2045 traffic noise levels for Build Alternative 1 are expected to be within 13 dBA of existing noise levels. An increase of 9 dBA to a decrease of up to 13 dBA in future noise levels is predicted at sites in Ukumehame. An increase of up to 13 dBA to a decrease of up to 10 dBA in future noise levels



## FUTURE TRAFFIC NOISE LEVELS

is predicted at sites in Olowalu. The change in traffic noise levels throughout the project area is affected by an increase in future traffic noise levels; however, the primary factor is the new Honoapiʻilani Highway alignment included in Build Alternative 1. The NAC of 67 dBA  $L_{eq}(h)$  is not predicted to be approached or exceeded at any of the 60 modeled sites and no sites are predicted to experience a substantial increase impact resulting from an increase in traffic noise levels by 15 dBA over existing noise levels (Table 4-1). Worst-hour future traffic noise levels for the Build Alternative 1 range from 38 dBA to 62 dBA depending on the proximity of the receiver to Honoapiʻilani Highway. The highest noise levels are predicted to decrease from 69 dBA to 62 dBA in comparison to existing noise levels as a result of shifting Honoapiʻilani Highway farther away from most noise-sensitive land uses located closer to the existing Honoapiʻilani Highway alignment.

FIGURE 4-1. Modeled 2045 Noise Levels with the Project



Source: WSP, 2023



FUTURE TRAFFIC NOISE LEVELS

TABLE 4-1. Predicted Existing Worst-Hour Traffic Noise Levels

SITE ID	LOCATION / DESCRIPTION	NUMBER OF RECEIVERS REPRESENTED	HDOT NOISE ABATEMENT CATEGORY (CRITERION*)	MODELED EXISTING 2023 WORST-HOUR LEQ(H), DBA	MODELED NO BUILD 2045 WORST-HOUR LEQ(H), DBA	LEQ(H), DBA INCREASE (+) OR DECREASE (-)	MODELED BUILD ALT 1 2045 WORST-HOUR LEQ(H), DBA	LEQ(H), DBA INCREASE (+) OR DECREASE (-)	MODELED BUILD ALT 2 2045 WORST-HOUR LEQ(H), DBA	LEQ(H), DBA INCREASE (+) OR DECREASE (-)	MODELED BUILD ALT 3 2045 WORST-HOUR LEQ(H), DBA	LEQ(H), DBA INCREASE (+) OR DECREASE (-)	MODELED BUILD ALT 4 2045 WORST-HOUR LEQ(H), DBA	LEQ(H), DBA INCREASE (+) OR DECREASE (-)	IMPACT TYPE* (S, A/E, OR NONE) ALTS 1 TO 4
M1	Pāpalaua Wayside Park	1	C/66	60	61	1	52	-8	56	-4	56	-4	55	-5	None
M2	Ukumehame Beach Park	1	C/66	62	63	1	49	-13	53	-9	54	-8	45	-17	None
M3	Ukumehame Firing Range	1	E/71	46	48	2	55	9	52	6	52	6	55	9	None
M4	Residence at Paeki'i Pl.	1	B/66	41	42	1	45	4	42	1	42	1	51	10	None
M5	Residence at Pāhaku 'Aeko St.	1	B/66	41	42	1	43	2	42	1	42	1	48	7	None
M6	Residence/SOD Farm at Ehehene St.	2	B/66, E/71	46	48	2	51	5	49	3	49	3	57	11	None
M7	Residence at Ehehene St.	1	B/66	44	46	2	45	1	45	1	45	1	47	3	None
M8	Residence beyond Ehehene St.	1	B/66	39	40	1	40	1	40	1	39	0	41	2	None
M9	Ukumehame Cultural Reserve	1	C/66	38	39	1	39	1	38	0	38	0	39	1	None
M10	Olowalu Lanakila Hawaiian Church	1	C/66	56	58	2	51	-5	53	-3	52	-4	52	-4	None
M11	Residence at Olowalu Village Rd.	1	B/66	54	55	1	51	-3	53	-1	51	-3	50	-4	None
M12	Residence at Olowalu Village Rd.	1	B/66	59	61	2	49	-10	50	-9	49	-10	48	-11	None
M13	Residence at Olowalu Village Rd.	1	B/66	58	60	2	49	-9	50	-8	49	-9	47	-11	None
M14	Residence at Olowalu Village Rd.	1	B/66	57	59	2	49	-8	51	-6	49	-8	47	-10	None
M15	Residence at Olowalu Village Rd.	1	B/66	57	58	1	50	-7	51	-6	48	-9	47	-10	None
M16	Residence at Olowalu Village Rd.	1	B/66	57	58	1	50	-7	51	-6	48	-9	47	-10	None
M17	Residence at Olowalu Village Rd.	1	B/66	60	61	1	50	-10	51	-9	48	-12	47	-13	None
M18	Residence at Olowalu Village Rd.	1	B/66	54	55	1	50	-4	52	-2	49	-5	48	-6	None
M19	Residence at Olowalu Village Rd.	1	B/66	55	56	1	50	-5	51	-4	49	-6	48	-7	None
M20	Residence at Olowalu Village Rd.	1	B/66	53	55	2	50	-3	52	-1	50	-3	48	-5	None
M21	Residence at Olowalu Village Rd.	1	B/66	53	54	1	51	-2	53	0	51	-2	49	-4	None
M22	Residence at Olowalu Village Rd.	1	B/66	60	62	2	51	-9	50	-10	49	-11	48	-12	None
M23	Olowalu Beach	1	C/66	50	51	1	47	-3	46	-4	46	-4	45	-5	None
M24	Camp Olowalu	1	C/66	56	58	2	50	-6	49	-7	48	-8	48	-8	None
M25	Residence at Olowalu Village Rd.	1	B/66	48	49	1	46	-2	44	-4	44	-4	44	-4	None
M26	Residence at Olowalu Village Rd.	1	B/66	48	50	2	47	-1	45	-3	44	-4	44	-4	None
M27	Residence at Olowalu Village Rd.	1	B/66	49	51	2	48	-1	45	-4	43	-6	44	-5	None
M28	Olowalu Landing	1	C/66	47	49	2	47	0	44	-3	42	-5	42	-5	None
M29	Commercial - Plantation House	1	E/71	48	49	1	49	1	44	-4	42	-6	43	-5	None
M30	Residence at Kuahulu Pl.	1	B/66	51	52	1	52	1	45	-6	43	-8	43	-8	None
M31	Residence at Kuahulu Pl.	1	B/66	49	51	2	52	3	45	-4	43	-6	43	-6	None
M32	Residence at Kuahulu Pl.	1	B/66	48	50	2	51	3	45	-3	42	-6	42	-6	None
M33	Commercial - Leoda's Kitchen and Pie Shop	1	E/71	66	68	2	58	-8	55	-11	55	-11	55	-11	None
M34	Residence/ Commercial - Olowalu General Store	2	B/66, E/71	65	67	2	58	-7	54	-11	54	-11	54	-11	None



FUTURE TRAFFIC NOISE LEVELS

SITE ID	LOCATION / DESCRIPTION	NUMBER OF RECEIVERS REPRESENTED	HDOT NOISE ABATEMENT CATEGORY (CRITERION*)	MODELED EXISTING 2023 WORST-HOUR LEQ(H), DBA	MODELED NO BUILD 2045 WORST-HOUR LEQ(H), DBA	LEQ(H), DBA INCREASE (+) OR DECREASE (-)	MODELED BUILD ALT 1 2045 WORST-HOUR LEQ(H), DBA	LEQ(H), DBA INCREASE (+) OR DECREASE (-)	MODELED BUILD ALT 2 2045 WORST-HOUR LEQ(H), DBA	LEQ(H), DBA INCREASE (+) OR DECREASE (-)	MODELED BUILD ALT 3 2045 WORST-HOUR LEQ(H), DBA	LEQ(H), DBA INCREASE (+) OR DECREASE (-)	MODELED BUILD ALT 4 2045 WORST-HOUR LEQ(H), DBA	LEQ(H), DBA INCREASE (+) OR DECREASE (-)	IMPACT TYPE* (S, A/E, OR NONE) ALTS 1 TO 4
M35	Commercial - The Maui Butterfly Farm	1	E/71	65	66	1	58	-7	53	-12	53	-12	53	-12	None
M36	Commercial - Olowalu Juice Stand	1	E/71	69	70	1	60	-9	58	-11	58	-11	58	-11	None
M37	Residence at Luawai St.	1	B/66	41	42	1	45	4	44	3	45	4	45	4	None
M38	Residence at Luawai St.	1	B/66	43	45	2	48	5	47	4	47	4	47	4	None
M39	Residence at Luawai St.	1	B/66	43	44	1	47	4	46	3	46	3	47	4	None
M40	Residence at Luawai St.	1	B/66	43	44	1	47	4	46	3	46	3	46	3	None
M41	Residence at Luawai St.	1	B/66	42	44	2	49	7	47	5	48	6	49	7	None
M42	Residence at Luawai St.	1	B/66	43	44	1	46	3	46	3	45	2	46	3	None
M43	Residence at Luawai St.	1	B/66	43	44	1	47	4	46	3	46	3	48	5	None
M44	Residence at Luawai St.	1	B/66	42	43	1	45	3	46	4	45	3	47	5	None
M45	Residence at Luawai St.	1	B/66	41	42	1	44	3	43	2	43	2	43	2	None
M46	Residence at Kalai Pl.	1	B/66	41	42	1	43	2	43	2	43	2	43	2	None
M47	Residence at Kalai Pl.	1	B/66	41	43	2	44	3	43	2	43	2	43	2	None
M48	Residence at Kalai Pl.	1	B/66	43	44	1	46	3	45	2	45	2	46	3	None
M49	Residence at Luawai St.	1	B/66	42	43	1	44	2	44	2	44	2	44	2	None
M50	Residence at Luawai St.	1	B/66	42	44	2	45	3	45	3	45	3	45	3	None
M51	Residence at Kalai Pl.	1	B/66	41	42	1	43	2	43	2	42	1	42	1	None
M52	Residence at Kalai Pl.	1	B/66	40	42	2	43	3	43	3	42	2	42	2	None
M53	Olowalu Cultural Reserve	1	C/66	35	36	1	38	3	39	4	40	5	40	5	None
M54	Residence at Luawai St.	1	B/66	36	37	1	38	2	40	4	44	8	44	8	None
M55	Olowalu Petroglyphs	7	C/66	36	37	1	38	2	41	5	48	12	51	15	<b>S - Alt 4</b>
M56	Residence at Luawai St.	1	B/66	41	42	1	44	3	53	12	53	12	51	10	None
M57	Residence at Luawai St.	1	B/66	41	43	2	44	3	54	13	51	10	50	9	None
M58	Awalua Cemetery	1	C/66	46	47	1	51	5	51	5	45	-1	46	0	None
M59	Commercial - Paintball	1	E/71	49	51	2	62	13	53	4	49	0	50	1	None
M60	Residence at Olowalu Village Rd.	1	B/66	45	47	2	54	9	51	6	46	1	46	1	None

Source: WSP, 2023.

Note: See Table 16-2 for descriptions of Noise Abatement Categories.

**Bold** = level approaches or exceeds the NAC or reach substantial increase impact of 15 dBA or above compared to existing conditions noise levels.

The calculation of dwelling units represented by site M55 were calculated using HDOT's method of comparing the impact area (estimated at 30,000 square feet) to the typical urban lot size of 4,200 square feet when required to determine noise barrier feasibility and reasonableness.

A "Receiver" is an area of frequent human outdoor activity, homes, apartments, parks, etc.

\*Impact Type: S = Substantial Increase (15 dBA or more), A/E = Approach or Exceed NAC.





#### **4.1.4 Build Alternative 2**

Predicted 2045 traffic noise levels for Build Alternative 2 are expected to be within 13 dBA of existing noise levels. An increase of 6 dBA to a decrease of up to 9 dBA in future noise levels is predicted at sites in Ukumehame. An increase of up to 13 dBA to a decrease of up to 12 dBA in future noise levels is predicted at sites in Olowalu. The change in traffic noise levels throughout the project route is affected by an increase in future traffic noise levels; however, the primary factor is the new Honoapi'ilani Highway alignment included in Build Alternative 2. The NAC of 67 dBA  $L_{eq}(h)$  is not predicted to be approached or exceeded at any of the 60 modeled sites, and no sites are predicted to experience a substantial increase impact resulting from an increase in traffic noise levels by 15 dBA over existing noise levels (Table 4-1). Worst-hour future traffic noise levels for Build Alternative 2 range from 38 dBA to 58 dBA depending on the proximity of the receiver to Honoapi'ilani Highway. The highest noise levels are predicted to decrease from 69 dBA to 58 dBA in comparison to existing noise levels as a result of shifting Honoapi'ilani Highway farther away from most noise-sensitive land uses located closer to the existing Honoapi'ilani Highway alignment.

#### **4.1.5 Build Alternative 3**

Predicted 2045 traffic noise levels for Build Alternative 3 are expected to be within 12 dBA of existing noise levels. An increase of 6 dBA to a decrease of up to 8 dBA in future noise levels is predicted at sites in Ukumehame. An increase of up to 12 dBA to a decrease of up to 12 dBA in future noise levels is predicted at sites in Olowalu. The change in traffic noise levels throughout the project route is affected by an increase in future traffic noise levels; however, the primary factor is the new Honoapi'ilani Highway alignment included in Build Alternative 3. The NAC of 67 dBA  $L_{eq}(h)$  is not predicted to be approached or exceeded at any of the 60 modeled sites and no sites are predicted to experience a substantial increase impact resulting from an increase in traffic noise levels by 15 dBA over existing noise levels (Table 4-1). Worst-hour future traffic noise levels for Build Alternative 3 range from 38 dBA to 58 dBA depending on the proximity of the receiver to Honoapi'ilani Highway. The highest noise levels are predicted to decrease from 69 dBA to 58 dBA in comparison to existing noise levels as a result of shifting Honoapi'ilani Highway farther away from most noise-sensitive land uses located closer to the existing Honoapi'ilani Highway alignment.

#### **4.1.6 Build Alternative 4**

Predicted 2045 traffic noise levels for Build Alternative 4 are expected to be within 17 dBA of existing noise levels. An increase of 11 to a decrease of up to 17 dBA in future noise levels is predicted at sites in Ukumehame. An increase of up to 15 dBA to a decrease of up to 13 dBA in future noise levels is predicted at sites in Olowalu. The change in traffic noise levels throughout the project route is affected by an increase in future traffic noise levels; however, the primary factor is the new Honoapi'ilani Highway alignment included in Build Alternative 4. The NAC of 67 dBA  $L_{eq}(h)$  is not predicted to be approached or exceeded at any of the 60 modeled sites. One site, the Olowalu Petroglyphs, represented by modeled site M55, is predicted to experience a substantial increase impact resulting from an increase in traffic noise levels of 15 dBA over existing noise levels (Table 4-1). Worst-hour future traffic noise levels for Build Alternative 4 range from 39 dBA to 58 dBA depending on the proximity

of the receiver to Honoapiʻilani Highway. The highest noise levels are predicted to decrease from 69 dBA to 59 dBA in comparison to existing noise levels as a result of shifting Honoapiʻilani Highway farther away from most noise-sensitive land uses located closer to the existing Honoapiʻilani Highway alignment.

## 4.2 COMPARATIVE ASSESSMENT

Predicted 2045 traffic noise levels for the four Build Alternatives are largely the same, with the highest noise levels of 62 dBA predicted at one commercial site, Maui Paintball located in Olowalu. Build Alternative 4 has the highest increase in noise levels over existing noise levels (15 dBA at the Olowalu Petroglyphs) and one impact (substantial increase at the Olowalu Petroglyphs). All four Build Alternatives would not result in any NAC impacts and all alternatives would lower the highest traffic noise levels by 8 dBA to 12 dBA as compared to existing conditions.



## Chapter 5 NOISE ABATEMENT MEASURES

Noise abatement measures must be considered as part of the Project if traffic noise impacts are identified and should be provided where it is feasible and reasonable to do so. Impacts occur at sites where traffic noise levels approach or exceed the NAC of  $L_{eq}(h)$  67 dBA, or substantially exceed (by 15 dBA or more) the ambient noise levels. HDOT's Highway Noise Policy and Abatement Guidelines are used to determine whether noise abatement measures can be implemented, depending on whether these measures are reasonable and feasible based on the following criteria:<sup>6</sup>

- Provide at least 5 dBA highway traffic noise reduction for two-thirds of front-row receptors located along the subject Type I project.
- Determination that it is possible to design and construct the barrier after considering issues related to safety, barrier height, topography, drainage, utilities, maintenance, maintenance access to adjacent properties, and access to adjacent properties.
- Consideration of viewpoints of the property owners and residents benefited by the barrier.
- Cost of noise abatement does not exceed \$60,000 per benefited receptor.
- Achieve noise reduction design goal of 7 dBA for 75% of the benefited front-row receptors located along the subject project.

The noise abatement evaluated for the project is based on a planning level cost estimate of the feasible abatement measures identified in this Draft EIS. The price per square foot of noise barrier construction is based on the average cost of HDOT's two most recent noise barriers constructed in 2010 (\$42.00) along with an escalation of construction cost of 3% per year (\$61.68 in 2023).

After determining whether each evaluated noise barrier can satisfy HDOT's feasibility criteria, each feasible noise barrier was then evaluated by comparing the maximum allowable cost to the construction cost estimate. If any barrier meets cost-reasonableness criteria, adjoining property owners would be consulted to determine whether a barrier is desired by the residents. A noise barrier is deemed reasonable only if the estimated cost is less than the maximum allowable cost and a majority of the residents want a barrier.

### 5.1 NOISE ABATEMENT EVALUATION: 2045 BUILD ALTERNATIVES

Based on the predicted 2045 traffic noise levels, one of the 60 modeled sites (modeled site M55) is predicted to reach the 15 dBA substantial increase threshold when compared to existing noise levels. Future worst-hour noise levels at the Olowalu Petroglyphs site (modeled site M55) are predicted to be

---

<sup>6</sup> State of Hawaii Department of Transportation (HDOT). 2016. Highway Noise Policy and Abatement Guidelines. April 2016.

51 dBA, as compared to 36 dBA under existing conditions. The substantial increase impact at the Olowalu Petroglyphs is only predicted under Build Alternative 4.

All sites predicted to have a noise impact require the evaluation of noise abatement. One noise barrier was evaluated for Build Alternative 4 to reduce traffic noise levels at the Olowalu Petroglyphs site. The location of the evaluated noise barrier for Build Alternative 4 (Noise Barrier 1) is presented in Figure 16-4. A summary of the noise barrier evaluation is provided below.

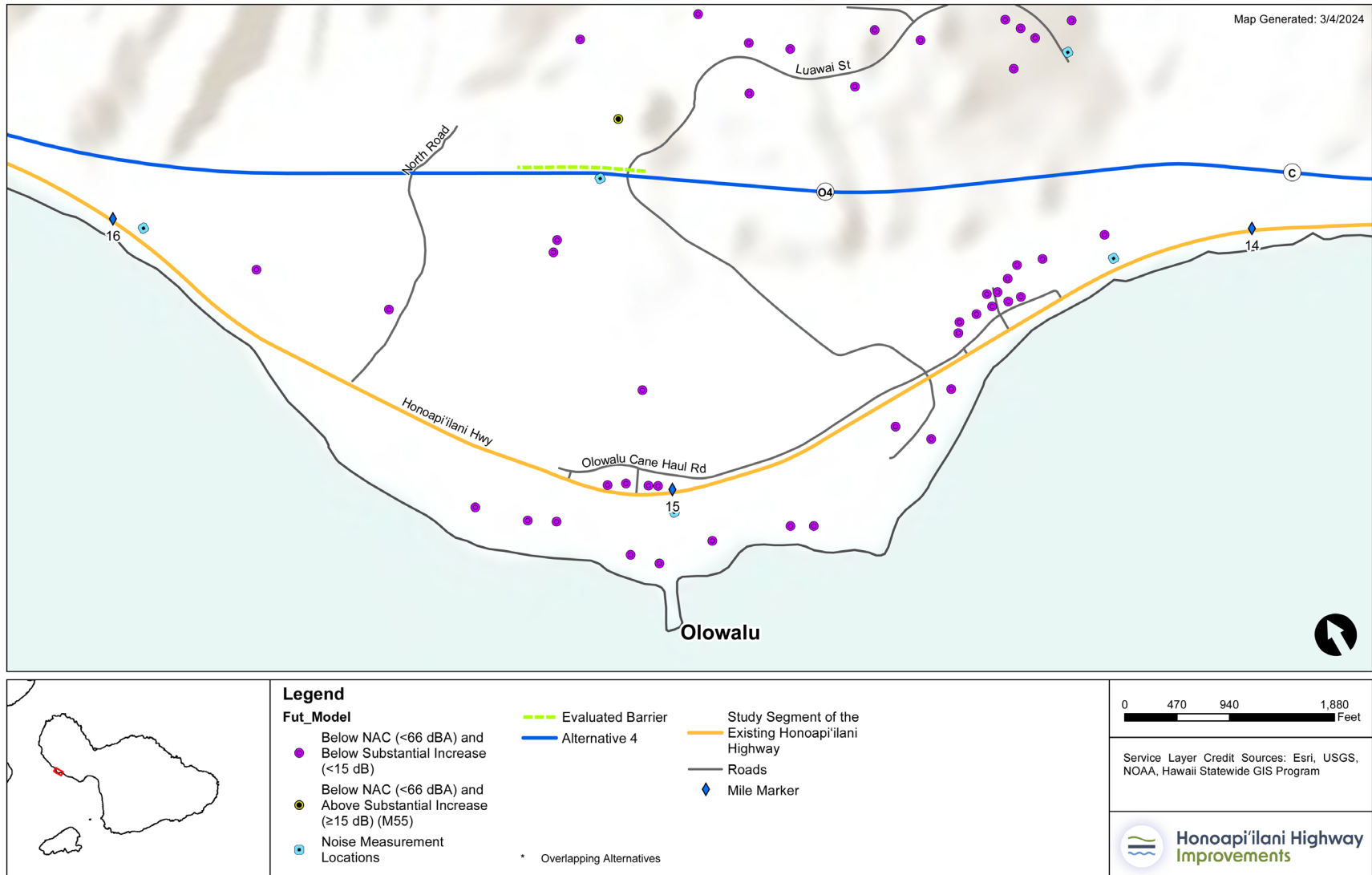
#### **5.1.1 Noise Barrier 1, Build Alternative 4**

Noise Barrier 1 was evaluated along the northbound Honoapiʻilani Highway right-of-way at the top of slope north of Luawai Street (FIGURE 5-1) to mitigate for noise impacts at site M55. The analysis considered a barrier length of approximately 1,076 linear feet at heights from 8 feet to 20 feet. At 20 feet high, Noise Barrier 1 would provide at least 5 dBA reduction to the one front-row receptor and is constructible based on a planning level review and is therefore feasible. At 20 feet high and 1,076 feet in length, Noise Barrier 1 meets the 7-dBA noise reduction design goal by providing at least a 7-dBA reduction to at least 75% of the benefited first row receptors located behind the barrier. At an allowance of \$60,000 per benefited residence or residential equivalent, the maximum allowance for Noise Barrier 1 is \$420,000. The calculation of dwelling units represented by site M55 were calculated using HDOT's method of comparing the impact area (estimated at 30,000 square feet) to the typical urban lot size of 4,200 square feet when required to determine noise barrier feasibility and reasonableness.

A planning level cost of \$61.68 per square feet was used for Noise Barrier 1. The planning level cost estimate for Noise Barrier 1 is \$1,327,353; therefore, the barrier is not reasonable relative to HDOT's cost per benefited receptor allowance. Barrier heights below 20 feet were evaluated, but would not provide the required benefit to meet HDOT's 7-dBA noise reduction design goal. Therefore, Noise Barrier 1 is deemed not reasonable under HDOT's Highway Noise Policy and Abatement Guidelines and will not be included in the Project.



FIGURE 5-1. Evaluated Noise Barrier Location, Build Alternative 4



Source: WSP, 2023

### **5.1.2 Preliminary Noise Mitigation Findings / Statement of Likelihood**

A substantial increase impact of 15 dBA or more above existing conditions is predicted at the Olowalu Petroglyphs site (modeled site M55) with Build Alternative 4. No other substantial increase impacts or impacts are predicted to approach or exceed the FHWA noise abatement criteria with any other Build Alternative.

One noise barrier was evaluated to reduce traffic noise levels at the one site where noise impacts were predicted with the Project (Build Alternative 4). The evaluated noise barrier was able to achieve the necessary noise reduction to satisfy HDOT Feasibility Criteria; however, the maximum allowance for the evaluated noise barrier that met feasibility was below the planning level cost estimate and will not be considered for placement as part of the Project. Details of each barrier evaluation is provided in Chapter 5 of this report.



## Chapter 6 CONSTRUCTION NOISE IMPACTS

Noise generated from construction activities will be determined on up to six sensitive receptors within the study area utilizing FHWA’s Roadway Construction Noise Model. Construction for the new Honoapi'ilani Highway involves the use of heavy machinery that may result in increased noise levels to adjacent noise sensitive land uses.

HDOH maintains community noise control standards (HAR §11-46) that also apply to construction noise. These specifications would be adhered to, and a noise permit would be obtained for construction activities performed during standard work hours (Monday through Friday 7:00 a.m. to 6:00 p.m. and Saturday 9:00 a.m. to 6:00 p.m.).

The duration and level of construction noise is dependent on the type of activity being performed. Construction activities such as drilling, excavation, and grading would typically be associated with increased noise levels whereas paving and restriping are generally less noise intensive activities.

Areas where drilling, excavating, and grading are planned would be anticipated to generate the highest noise levels during construction. Noise generated by construction equipment, including trucks, graders, excavators, drilling equipment, concrete mixers, and generators can reach levels from 76 A-weighted decibels (dBA) to 85 dBA at a distance of 50 feet. Construction equipment noise emissions are regulated by the Environmental Protection Agency’s Noise Control Program (Title 40 Code of Federal Regulations Part 204). Presently, air compressors are the only equipment under regulation, and no new regulations are under consideration.

Noise levels for equipment that could be used during the excavation and construction of the Project are presented in Table 6-1. The noise levels presented are at a reference distance of 50 feet. Construction equipment noise levels decrease at a rate of approximately 6 dBA per doubling of distance; therefore, at a distance of 100 feet the noise levels would be about 6 dBA less than the levels shown in the table. Similarly, at a distance of 200 feet the noise levels would be approximately 12 dBA less than shown in the table. Intervening structures or topography can act as a noise barrier to further reduce noise levels.

TABLE 6-1. Construction Equipment Noise Levels

Equipment	DECIBELS AT 50 FEET	EQUIPMENT	DECIBELS AT 50 FEET
Air Compressor	78	Generator	81
Auger Drill Rig	84	Gradall	83
Backhoe	78	Grader	85
Blasting	94	Jack Hammer	89

Equipment	DECIBELS AT 50 FEET	EQUIPMENT	DECIBELS AT 50 FEET
Compactor	83	Hoe Ram	90
Concrete Mixer Truck	79	Paver	77
Concrete Pump Truck	81	Pneumatic Tool	85
Crane	81	Pump	81
Dozer	82	Rock Drill	81
Drill Rig Truck	84	Roller	80
Dump Truck	76	Scraper	84
Excavator	81	Ventilation Fan	79
Flat Bed Truck	74		

Source: FHWA Roadway Construction Noise Model, 2006.

The State of Hawaiʻi Department of Health (DOH) maintains community noise control standards that apply to construction noise. The project is not allowed to exceed the stipulated noise limits unless a variance is granted by the DOH.

Noise control measures during construction would be implemented to minimize construction noise and the effect on existing noise-sensitive land uses. The general noise abatement measures presented below are identified as guidance to be used in the development of construction plans.

1. Design Considerations - During the early stages of construction plan development, strategic placement of stationary equipment, such as compressors and generators, can be considered for use as shielding against construction noise.
2. Source Control - The contractor would comply with HDOT Standard Specifications and all local sound control and noise level rules, regulations, and ordinances which apply to work performed pursuant to the contract. Each internal combustion engine used for any purpose on the job, or related to the job, would be equipped with a muffler of a type recommended by the manufacturer. No internal combustion engine would be operated without a muffler.
3. Community Relations - Community meetings can be held to explain the construction work, time involved, and the control measures to be taken to reduce noise associated with construction.

The aforementioned measures would be incorporated into site-specific construction plans, and additional noise emission limits could be developed as well.





## REFERENCES

## REFERENCES

County of Maui's Automated Planning & Permitting System (MAPPS); Online research of building permits within the Project study area at: [https://mapps.co.maui.hi.us/energov\\_prod/selfservice/MauiCountyHIProd#/search](https://mapps.co.maui.hi.us/energov_prod/selfservice/MauiCountyHIProd#/search) on March 19, 2023.

State of Hawai'i, Department of Transportation (HDOT), Highways Divisions; *Highway Noise Policy and Abatement Guidelines*, April, 2016.

State of Hawai'i, Department of Transportation (HDOT), Highways Divisions; Traffic Data for use in the Traffic Noise Study, Email correspondence with Jillian Chen, HDOT Highways Division, November and December, 2019.

U.S. Department of Transportation, Federal Highway Administration (FHWA), 1973. *Fundamentals and Abatement of Highway Traffic Noise*. Washington D.C.

U.S. Department of Transportation, Federal Highway Administration (FHWA), 1982. "Procedures for Abatement of Highway Traffic Noise and Construction Noise." Washington, D.C.

U.S. Department of Transportation, Federal Highway Administration (FHWA), 1996. *Measurement of Highway-Related Noise*. Washington D.C.

U.S. Department of Transportation, Federal Highway Administration (FHWA), 1998, 2004. *FHWA Traffic Noise Model User's Guide*. Washington D.C.

U.S. Department of Transportation. Federal Highway Administration (FHWA). 2006. FHWA Highway Construction Noise Handbook and Roadway Construction Noise Model (version 1.0). Washington, D.C.

U.S. Department of Transportation, Federal Highway Administration (FHWA) directive "Highway Traffic Noise: Analysis and Abatement," Revised December 2010.

U.S. Code of Federal Regulations (CFR) Part 772 (23 CFR Part 772), July 2010.

U.S. Environmental Protection Agency (EPA), 1974. Information on Levels of Environmental Noise Requisite to Protect Public Health and Welfare with an Adequate Margin of Safety. Report Number 550/9-74-004.

United States Geological Survey (USGS), October 28, 2004. Last access online in June 2023 at: <http://seamless.usgs.gov/website/seamless/index.asp>.

WSP USA Inc. (WSP), 2023a. Preliminary Project Design Files for use in the Traffic Noise Modeling and Analysis. WSP Honolulu, HI, May 2020.

WSP USA Inc. (WSP), 2023b. Existing and future traffic data for use in the Traffic Noise Modeling and Analysis. WSP Honolulu, HI, May 2020.

## APPENDIX A – FIELD DATA SHEETS AND SITE PHOTOGRAPHS

Appendix A contains data sheets that describe noise measurements conducted in support of the noise analysis for the Honoapi'ilani Project from June 20, 2023 to June 22, 2023. The field data sheets include measured noise levels, descriptions of measurement activities and locations, site observations, site photographs, traffic data collected during all short-term measurements.

Field data sheets for sites ST-1 to ST-10 relate to short-term measurements conducted to validate the FHWA Traffic Noise Modeled developed for this project.

Field data sheets for sites LT-1 to LT-3 describe long-term measurement conducted in support of the traffic noise analysis and project construction. Appendix B contains hourly data plotted for each long-term measurement.



**APPENDIX A – FIELD DATA SHEETS AND SITE PHOTOGRAPHS**

**Noise Measurement Data Sheet**

Project Name: Honoapiʻilani Highway	Project Number: 31000290.000
Measurement Site: ST-1	Address: Near 256 Luawai St.
Staff: Romero, Yoshioka	Location: Luakwai Street, east terminus
Weather: Sunny with clouds, no precipitation	Temperature / Wind: 73°F / 0-4 mph mauka
Instrumentation / S/N: LD820 / 1194 LDCAL200 / 2239	Calibration Pre-Check: 114.0 Post-Check: 114.0
Date: 06/20/23	Start Time / Duration: 11:30 / 15-minute

**Sound Level Results**

Leq:	45.0
Lmax:	53.5
Lmin:	39.2
L90:	42.1
L50:	44.0
L10:	47.0
L1:	57.4

**Concurrent Traffic Count**

	Roadway / Direction Honohwy NB	Speed (mph)	Roadway / Direction Honohwy SB	Speed (mph)
Autos	152	55	226	55
Medium Trucks	3	55	3	55
Heavy Trucks	0	0	0	0
Motos	0	0	0	0
Buses	0	0	0	0

**Photographs:**



**Site Layout:**



**Notes:**

Measurement location not for model validation.
Traffic noise from Honoapiʻilani Highway not audible.
Noise assessment location at outdoor use areas of nearby residences.

**Noise Measurement Data Sheet**

Project Name: Honoapi'ilani Highway	Project Number: 31000290.000
Measurement Site: ST-2	Address: Approximately 224 feet from Luawai St.
Staff: Romero, Yoshioka	Location: Approximately 500 mauka from Olowalu Petroglyphs
Weather: Sunny with clouds, no precipitation	Temperature / Wind: 73°F / 0-6 mph mauka
Instrumentation / S/N: LD820 / 1194 LDCAL200 / 2239	Calibration Pre-Check: 114.0 Post-Check: 114.0
Date: 06/20/23	Start Time / Duration: 12:10 / 15-minute

**Sound Level Results**

Leq:	46.8
Lmax:	57.9
Lmin:	39.3
L90:	41.3
L50:	44.3
L10:	49.8
L1:	55.8

**Concurrent Traffic Count**

	Roadway / Direction	Speed (mph)	Roadway / Direction	Speed (mph)
	HonoHwy NB		HonoHwy SB	
Autos	152	55	226	55
Medium Trucks	3	55	3	55
Heavy Trucks	0	0	0	0
Motos	0	0	0	0
Buses	0	0	0	0

**Photographs:**



View makai.



View mauka.

**Site Layout:**



ST-2 approximately 224 feet from Luawai St.

**Notes:**

Measurement location not for model validation.
Traffic noise from Honoapi'ilani Highway not audible.
Noise assessment location at outdoor use area at Olowalu Petroglyphs.





APPENDIX A – FIELD DATA SHEETS AND SITE PHOTOGRAPHS

**Noise Measurement Data Sheet**

Project Name: Honoapi'ilani Highway	Project Number: 31000290.000
Measurement Site: ST-3	Address: Approximately 43 feet from Honoapi'ilani Highway
Staff: Romero, Yoshioka	Location: Papalaua Wayside Park
Weather: Sunny with clouds, no precipitation	Temperature / Wind: 73°F / 0-4 mph mauka
Instrumentation / S/N: LD820 / 1194 LDCAL200 / 2239	Calibration Pre-Check: 114.0 Post-Check: 114.0
Date: 06/20/23	Start Time / Duration: 2:30 / 15-minute

**Sound Level Results**

Leq:	71.3
Lmax:	83.9
Lmin:	58.2
L90:	65.3
L50:	70.4
L10:	73.8
L1:	77.9

**Concurrent Traffic Count**

	Roadway / Direction	Speed (mph)	Roadway / Direction	Speed (mph)
	HonoHwy NB		HonoHwy SB	
Autos	250	45	237	45
Medium Trucks	1	45	10	45
Heavy Trucks	0	0	0	0
Motos	1	45	0	0
Buses	0	0	0	0

**Photographs:**



View makai.



View mauka.

**Site Layout:**



ST-3 approximately 43 feet from traveling lanes on Honoapi'ilani Highway.

**Notes:**

Measurement location for model validation.
Traffic noise from Honoapi'ilani Highway was primary noise source during measurement.
Noise assessment location at Papalaua Wayside Park.

**Noise Measurement Data Sheet**

Project Name: Honoapi'ilani Highway	Project Number: 31000290.000
Measurement Site: ST-4	Address: Near 383 Pohaku Aeko St.
Staff: Romero, Yoshioka	Location: Approximately 14 feet from Pohaku Aeko St.
Weather: Sunny with clouds, no precipitation	Temperature / Wind: 74°F / 0-3 mph mauka
Instrumentation / S/N: LD820 / 1194 LDCAL200 / 2239	Calibration Pre-Check: 114.0 Post-Check: 114.0
Date: 06/20/23	Start Time / Duration: 2:55 / 15-minute

**Photographs:**



View makai.



View mauka.

**Sound Level Results**

Leq:	44.3
Lmax:	57.2
Lmin:	39.9
L90:	41.1
L50:	42.6
L10:	46.6
L1:	51.8

**Concurrent Traffic Count**

	Roadway / Direction	Speed (mph)	Roadway / Direction	Speed (mph)
	HonoHwy NB		HonoHwy SB	
Autos	250	45	237	45
Medium Trucks	1	45	10	45
Heavy Trucks	0	0	0	0
Motos	0	0	0	0
Buses	0	0	0	0

**Site Layout:**



**Notes:**

Measurement location not for model validation.
Traffic noise from Honoapi'ilani Highway was not audible during measurement.
Noise assessment location at nearby residence.





APPENDIX A – FIELD DATA SHEETS AND SITE PHOTOGRAPHS

**Noise Measurement Data Sheet**

Project Name: Honoapi'ilani Highway	Project Number: 31000290.000
Measurement Site: ST-5	Address: Adjacent to Olowalu Lanakila Hawaiian Church
Staff: Romero, Yoshioka	Location: Approximately 75 feet from Honoapi'ilani Highway
Weather: Sunny with clouds, no precipitation	Temperature / Wind: 75°F / 0-2 mph mauka
Instrumentation / S/N: LD820 / 1194 LDCAL200 / 2239	Calibration Pre-Check: 114.0 Post-Check: 114.0
Date: 06/20/23	Start Time / Duration: 3:35 / 15-minute

**Sound Level Results**

Leq:	63.4
Lmax:	73.8
Lmin:	52.1
L90:	59.4
L50:	62.5
L10:	65.8
L1:	69.5

**Concurrent Traffic Count**

	Roadway / Direction	Speed (mph)	Roadway / Direction	Speed (mph)
	HonoHwy NB		HonoHwy SB	
Autos	251	45	302	45
Medium Trucks	5	45	6	45
Heavy Trucks	1	45	1	45
Motos	1	45	0	0
Buses	0	0	0	0

**Photographs:**



View makai.



View mauka.

**Site Layout:**



ST-5 approximately 75 feet from traveling lanes on Honoapi'ilani Highway.

**Notes:**

Measurement location for model validation.
Traffic noise from Honoapi'ilani Highway was primary noise source during measurement.
Noise assessment location at outdoor use areas at church and nearby residences.

**Noise Measurement Data Sheet**

Project Name: Honoapi'ilani Highway	Project Number: 31000290.000
Measurement Site: ST-6	Address: Paeki'i Place cul-de-sac.
Staff: Romero, Yoshioka	Location: Approximately 34 feet Paeki'i Place edge of pavement.
Weather: Sunny with clouds, no precipitation	Temperature / Wind: 70°F / 0-1 mph mauka
Instrumentation / S/N: LD820 / 1194 LDCAL200 / 2239	Calibration Pre-Check: 114.0 Post-Check: 114.0
Date: 06/21/23	Start Time / Duration: 11:50 / 15-minute

**Sound Level Results**

Leq:	47.1
Lmax:	70.9
Lmin:	39.3
L90:	41.1
L50:	43.4
L10:	46.8
L1:	58.0

**Concurrent Traffic Count**

	Roadway / Direction	Speed (mph)	Roadway / Direction	Speed (mph)
	HonoHwy NB		HonoHwy SB	
Autos	244	45	244	45
Medium Trucks	1	45	3	45
Heavy Trucks	3	40	3	40
Motos	0	0	0	0
Buses	0	0	0	0

**Photographs:**



View makai.



View mauka.

**Site Layout:**



ST-6 approximately 34 feet from Paeki'i Place edge of pavement.

**Notes:**

Measurement location not for model validation.
Traffic noise from Honoapi'ilani Highway was not audible during measurement.
Noise assessment location at nearby residence.





**APPENDIX A – FIELD DATA SHEETS AND SITE PHOTOGRAPHS**

**Noise Measurement Data Sheet**

Project Name: Honoapi'ilani Highway	Project Number: 31000290.000
Measurement Site: ST-7	Address: 615 HI-30 Lahaina
Staff: Romero, Yoshioka	Location: Ukumehame Beach Park
Weather: Sunny with clouds, no precipitation	Temperature / Wind: 71°F / 0-6 mph mauka
Instrumentation / S/N: LD820 / 1194 LDCAL200 / 2239	Calibration Pre-Check: 114.0 Post-Check: 114.0
Date: 06/21/23	Start Time / Duration: 12:55 / 15-minute

**Sound Level Results**

Leq:	65.6
Lmax:	80.8
Lmin:	55.0
L90:	59.6
L50:	63.4
L10:	68.0
L1:	74.0

**Concurrent Traffic Count**

	Roadway / Direction	Speed (mph)	Roadway / Direction	Speed (mph)
	HonoHwy NB		HonoHwy SB	
Autos	238	45	208	45
Medium Trucks	5	45	12	45
Heavy Trucks	2	45	0	0
Motos	1	45	1	45
Buses	0	0	0	0

**Photographs:**



View makai.



View mauka.

**Site Layout:**



ST-7 approximately 50 feet from nearest traveling lane on Honoapi'ilani Highway.

**Notes:**

Measurement location for model validation.
Traffic noise from Honoapi'ilani Highway was the primary noise source during measurement.
Noise assessment location at outdoor use locations at Park.

**Noise Measurement Data Sheet**

Project Name: Honoapi'ilani Highway	Project Number: 31000290.000
Measurement Site: ST-8	Address: Approximately 100 feet from nearest traveling lane on Honoapi'ilani Highway
Staff: Romero, Yoshioka	Location: Southern terminus of former Honoapi'ilani Highway
Weather: Sunny with clouds, no precipitation	Temperature / Wind: 76°F / 0-6 mph mauka
Instrumentation / S/N: LD820 / 1194 LDCAL200 / 2239	Calibration Pre-Check: 114.0 Post-Check: 114.0
Date: 06/21/23	Start Time / Duration: 3:25 / 15-minute

**Sound Level Results**

Leq:	58.4
Lmax:	76.6
Lmin:	44.8
L90:	53.1
L50:	57.1
L10:	60.9
L1:	65.3

**Concurrent Traffic Count**

	Roadway / Direction	Speed (mph)	Roadway / Direction	Speed (mph)
	HonoHwy NB		HonoHwy SB	
Autos	267	50	271	50
Medium Trucks	5	50	4	50
Heavy Trucks	0	0	1	45
Motos	1	50	3	50
Buses	0	0	0	0

**Photographs:**



View makai.



View mauka.

**Site Layout:**



ST-8 approximately 100 feet from nearest traveling lane on Honoapi'ilani Highway.

**Notes:**

Measurement location for model validation.
Traffic noise from Honoapi'ilani Highway was the primary noise source during measurement.
Noise assessment location at outdoor use locations at Beach.





APPENDIX A – FIELD DATA SHEETS AND SITE PHOTOGRAPHS

**Noise Measurement Data Sheet**

Project Name: Honoapi'ilani Highway	Project Number: 31000290.000
Measurement Site: ST-9	Address: Approximately 145 feet from nearest traveling lane on Honoapi'ilani Highway
Staff: Romero, Yoshioka	Location: Olowalu Landing Parking
Weather: Sunny with clouds, no precipitation	Temperature / Wind: 76°F / 0-2 mph mauka
Instrumentation / S/N: LD820 / 1194 LDCAL200 / 2239	Calibration Pre-Check: 114.0 Post-Check: 114.0
Date: 06/21/23	Start Time / Duration: 3:55 / 15-minute

**Sound Level Results**

Leq:	60.1
Lmax:	66.3
Lmin:	53.5
L90:	56.8
L50:	59.6
L10:	62.1
L1:	64.6

**Concurrent Traffic Count**

	Roadway / Direction	Speed (mph)	Roadway / Direction	Speed (mph)
	HonoHwy NB		HonoHwy SB	
Autos	210	45	318	45
Medium Trucks	2	45	10	45
Heavy Trucks	0	0	0	0
Motos	0	0	0	0
Buses	0	0	0	0

**Photographs:**



View makai.



View mauka.

**Site Layout:**



**Notes:**

Measurement location for model validation.
Traffic noise from Honoapi'ilani Highway was the primary noise source during measurement.
Noise assessment location at beach and outdoor use locations at nearby residences.

**Noise Measurement Data Sheet**

Project Name: Honoapi'ilani Highway	Project Number: 31000290.000
Measurement Site: ST-10	Address: Approximately 85 feet from nearest traveling lane on Honoapi'ilani Highway
Staff: Romero, Yoshioka	Location: Dirt Road north of 814 HI- 30
Weather: Sunny with clouds, no precipitation	Temperature / Wind: 77°F / 0-4 mph mauka
Instrumentation / S/N: LD820 / 1194 LDCAL200 / 2239	Calibration Pre-Check: 114.0 Post-Check: 114.0
Date: 06/21/23	Start Time / Duration: 4:35 / 15-minute

**Sound Level Results**

Leq:	63.3
Lmax:	74.3
Lmin:	53.1
L90:	58.9
L50:	62.3
L10:	65.8
L1:	70.1

**Concurrent Traffic Count**

	Roadway / Direction	Speed (mph)	Roadway / Direction	Speed (mph)
	HonoHwy NB		HonoHwy SB	
Autos	254	45	324	45
Medium Trucks	4	45	7	45
Heavy Trucks	0	0	0	0
Motos	0	0	1	45
Buses	0	0	0	0

**Photographs:**

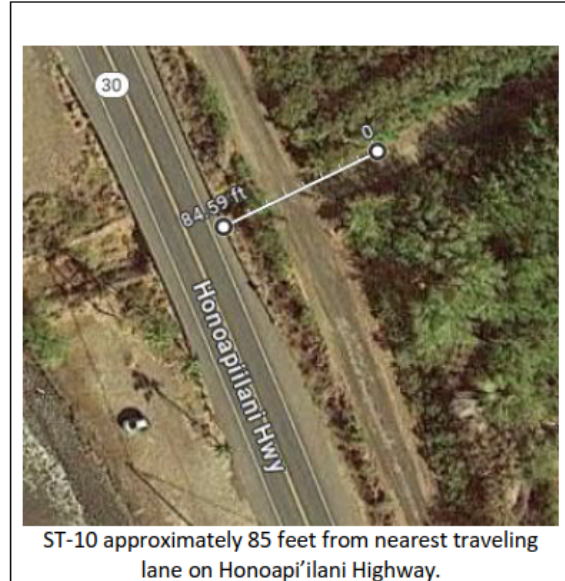


View makai.



View mauka.

**Site Layout:**



ST-10 approximately 85 feet from nearest traveling lane on Honoapi'ilani Highway.

**Notes:**

Measurement location for model validation.
Traffic noise from Honoapi'ilani Highway was the primary noise source during measurement.
Noise assessment location at beach and outdoor use locations at nearby residences.





APPENDIX A – FIELD DATA SHEETS AND SITE PHOTOGRAPHS

**Noise Measurement Data Sheet**

Project Name: Honoapiʻilani Highway	Project Number: 31000290.000
24-Hour Noise Measurements: LT-1	Address: 820 Olowalu Village Rd, Lahaina, HI 96761
Staff: Romero, Yoshioka	Location: The Maui Butterfly Farm
Weather: Partly cloudy, no precipitation	Temperature / Wind (mph): 73°F / variable
Instrumentation / S/N: LD720 / 0161 LDCAL200 / 2239	Calibration Pre-Check: 114.0 Post-Check: 114.0
Date: 6/20/2023 – 6/21/2023	Start Time / Duration: 11:00 a.m. / 24-hour

**Sound Level Results**

LDN:	69
Daytime Average:	65.5
Nighttime Average:	61.7
Peak Hour:	68
Peak Hour Time:	7:00 a.m.

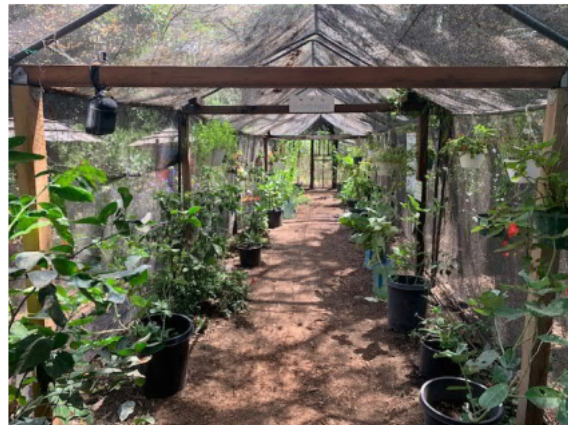
**Site Layout**



**Photographs**



View makai towards Honoapiʻilani Highway. Pelican case containing sound level meter hanging on right.



View mauka away from Honoapiʻilani Highway. Pelican case containing sound level meter hanging on right.

**Notes:**

Sound level meter contained in Pelican case with mic running outside to collect hourly noise levels. Measurement conducted from open-air butterfly enclosure screened with netting. Measured noise levels used to assess noise levels near Honoapiʻilani Highway.

**Noise Measurement Data Sheet**

Project Name: Honoapiʻilani Highway	Project Number: 31000290.000
24-Hour Noise Measurements: LT-2	Address: Adjacent to 255 Luawai St., Lahaina, HI 96761
Staff: Romero, Yoshioka	Location: Luawai St. terminus
Weather: Partly cloudy, no precipitation	Temperature / Wind (mph): 74°F / variable
Instrumentation / S/N: LD720 / 0514 LDCAL200 / 2239	Calibration Pre-Check: 114.0 Post-Check: 114.0
Date: 6/20/2023 – 6/21/2023	Start Time / Duration: 1:00 p.m. / 24-hour

**Sound Level Results**

LDN:	63
Daytime Average:	64.2
Nighttime Average:	49.9
Peak Hour:	73
Peak Hour Time:	9:00 p.m.

**Site Layout**



LT-2 located approximately 18 feet from Luawai St.

**Photographs**



View makai towards Honoapiʻilani Highway. Sound level meter in Pelican case hanging in tree to right of view.



View mauka away from Honoapiʻilani Highway. Sound level meter in Pelican case hanging in tree to left of view.

**Notes:**

Sound level meter contained in Pelican case with mic running outside to collect hourly noise levels. Measurement conducted from tree near Luawai St. Measured noise levels used to assess noise levels near Luawai St.





**APPENDIX A – FIELD DATA SHEETS AND SITE PHOTOGRAPHS**

**Noise Measurement Data Sheet**

Project Name: Honoapiʻilani Highway	Project Number: 31000290.000
24-Hour Noise Measurements: LT-3	Address: Paekiʻi Pl. cul-de-sac near 849 Paekiʻi Pl., Lahaina, HI 96761
Staff: Romero, Yoshioka	Location: Luawai St. terminus
Weather: Partly cloudy, no precipitation	Temperature / Wind (mph): 74°F / variable
Instrumentation / S/N: LD720 / 0161 LDCAL200 / 2239	Calibration Pre-Check: 114.0 Post-Check: 114.0
Date: 6/21/2023 – 6/22/2023	Start Time / Duration: 1:00 p.m. / 24-hour

**Sound Level Results**

LDN:	61
Daytime Average:	54.1
Nighttime Average:	54.7
Peak Hour:	60
Peak Hour Time:	9:00 a.m.

**Site Layout**



LT-3 located approximately 45 feet from center of Paekiʻi Pl. cul-de-sac.

**Photographs**



View makai towards Honoapiʻilani Highway. Sound level meter in Pelican case hanging in tree adjacent to Paekiʻi Pl. cul-de-sac.



View mauka away from Honoapiʻilani Highway to nearest residence at 849 Paekiʻi Pl.

**Notes:**

Sound level meter contained in Pelican case with mic running outside to collect hourly noise levels. Measurement conducted from tree adjacent to Paekiʻi Pl. cul-de-sac. Measured noise levels used to assess noise levels near Paekiʻi Pl.

## **APPENDIX B – LONG-TERM MEASUREMENT DATA**

The following information measurement data was collected in June of 2023 in support of the Honoapi'ilani Project to support the traffic noise analysis and project construction.





TABLE B-1A. Site LT1 - Hourly Noise Measured Levels

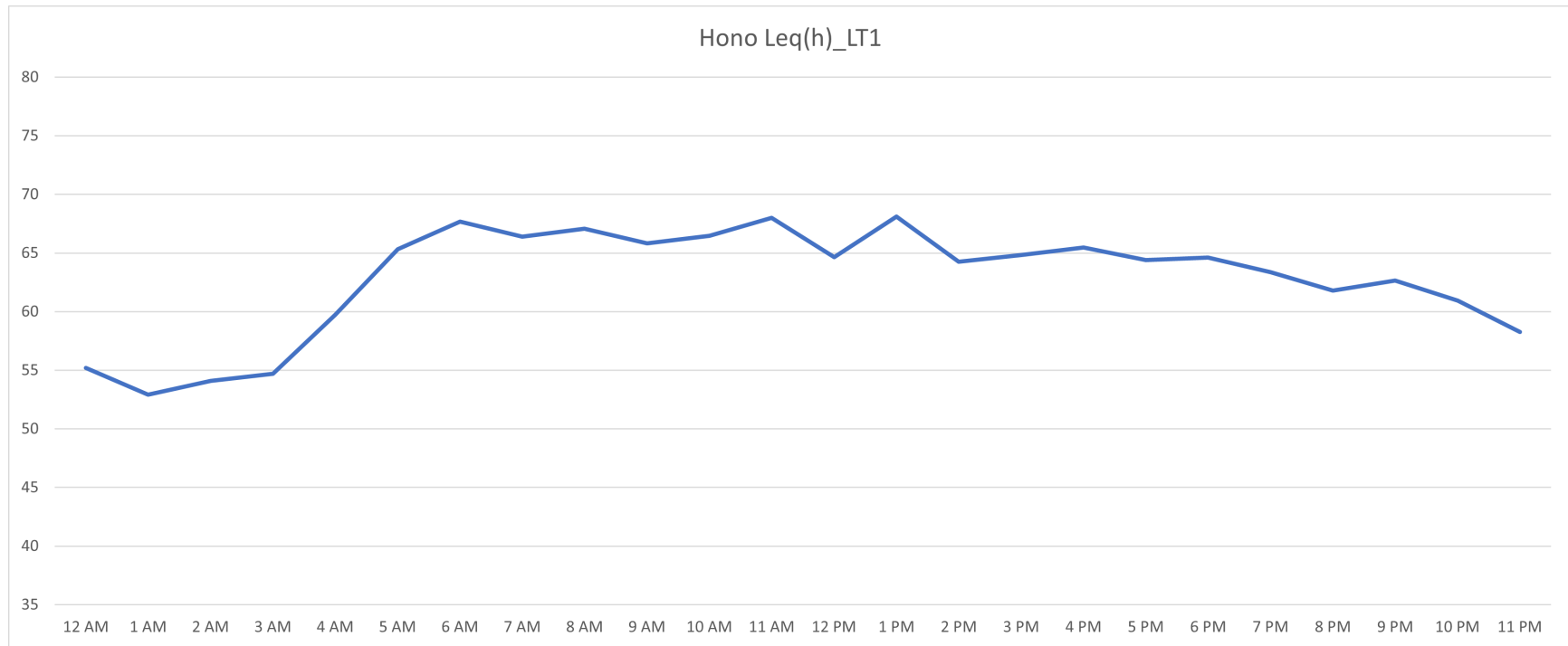
Site	Location	Number	Date	Time	Duration	Leq	Lmax	Lmin	Peak	L(1)	L(10)	L(50)	L(90)
Hono_LT1	Maui Butterfly Farm - 820 Olowalu Village Rd	LT1	21-Jun-23	0:00:00	3600	55.2	75.1	37.7	90.6	66.0	60.1	41.2	38.6
Hono_LT1	Maui Butterfly Farm - 820 Olowalu Village Rd	LT1	21-Jun-23	1:00:00	3600	52.9	76.5	38.0	95.2	64.9	55.1	40.0	38.5
Hono_LT1	Maui Butterfly Farm - 820 Olowalu Village Rd	LT1	21-Jun-23	2:00:00	3600	54.1	76.0	37.3	89.9	66.5	56.8	40.1	38.3
Hono_LT1	Maui Butterfly Farm - 820 Olowalu Village Rd	LT1	21-Jun-23	3:00:00	3600	54.7	72.8	37.2	87.8	66.1	59.3	42.3	38.4
Hono_LT1	Maui Butterfly Farm - 820 Olowalu Village Rd	LT1	21-Jun-23	4:00:00	3600	59.7	77.5	38.0	92.6	70.7	64.1	49.6	41.0
Hono_LT1	Maui Butterfly Farm - 820 Olowalu Village Rd	LT1	21-Jun-23	5:00:00	3600	65.3	80.4	41.7	94.8	74.3	69.0	62.5	51.4
Hono_LT1	Maui Butterfly Farm - 820 Olowalu Village Rd	LT1	21-Jun-23	6:00:00	3600	67.7	81.0	45.0	94.3	77.6	70.6	65.2	57.3
Hono_LT1	Maui Butterfly Farm - 820 Olowalu Village Rd	LT1	21-Jun-23	7:00:00	3600	66.4	86.4	47.0	101.7	73.3	68.9	65.0	59.3
Hono_LT1	Maui Butterfly Farm - 820 Olowalu Village Rd	LT1	21-Jun-23	8:00:00	3600	67.1	88.1	49.1	101.3	76.2	69.0	64.8	60.0
Hono_LT1	Maui Butterfly Farm - 820 Olowalu Village Rd	LT1	21-Jun-23	9:00:00	3600	65.8	81.9	50.7	95.4	73.4	68.1	64.6	60.8
Hono_LT1	Maui Butterfly Farm - 820 Olowalu Village Rd	LT1	21-Jun-23	10:00:00	3600	66.5	82.7	53.7	95.5	76.4	68.8	63.9	60.5
Hono_LT1	Maui Butterfly Farm - 820 Olowalu Village Rd	LT1	20-Jun-23	11:00:00	3600	68.0	94.3	53.5	106.2	77.8	69.2	65.3	61.0
Hono_LT1	Maui Butterfly Farm - 820 Olowalu Village Rd	LT1	20-Jun-23	12:00:00	3600	64.7	85.6	51.6	98.0	72.4	66.5	62.8	58.3
Hono_LT1	Maui Butterfly Farm - 820 Olowalu Village Rd	LT1	20-Jun-23	13:00:00	3600	68.1	86.6	50.6	97.3	80.2	68.7	63.5	59.0
Hono_LT1	Maui Butterfly Farm - 820 Olowalu Village Rd	LT1	20-Jun-23	14:00:00	3600	64.3	84.7	47.9	102.0	72.2	66.4	62.8	58.5
Hono_LT1	Maui Butterfly Farm - 820 Olowalu Village Rd	LT1	20-Jun-23	15:00:00	3600	64.8	84.2	49.9	92.9	72.5	67.4	63.4	59.2
Hono_LT1	Maui Butterfly Farm - 820 Olowalu Village Rd	LT1	20-Jun-23	16:00:00	3600	65.5	83.0	50.1	110.6	72.6	67.5	64.4	61.4
Hono_LT1	Maui Butterfly Farm - 820 Olowalu Village Rd	LT1	20-Jun-23	17:00:00	3600	64.4	75.1	46.6	90.9	70.5	66.8	63.7	58.8
Hono_LT1	Maui Butterfly Farm - 820 Olowalu Village Rd	LT1	20-Jun-23	18:00:00	3600	64.6	82.6	46.2	100.1	72.0	67.4	63.2	55.3
Hono_LT1	Maui Butterfly Farm - 820 Olowalu Village Rd	LT1	20-Jun-23	19:00:00	3600	63.4	84.2	41.6	99.2	71.6	66.0	61.8	49.6
Hono_LT1	Maui Butterfly Farm - 820 Olowalu Village Rd	LT1	20-Jun-23	20:00:00	3600	61.8	72.5	41.2	87.4	68.9	65.3	60.6	47.3
Hono_LT1	Maui Butterfly Farm - 820 Olowalu Village Rd	LT1	20-Jun-23	21:00:00	3600	62.7	79.1	39.2	94.1	71.2	65.9	61.0	45.8
Hono_LT1	Maui Butterfly Farm - 820 Olowalu Village Rd	LT1	20-Jun-23	22:00:00	3600	61.0	76.2	39.5	91.0	69.7	65.0	56.9	42.8
Hono_LT1	Maui Butterfly Farm - 820 Olowalu Village Rd	LT1	20-Jun-23	23:00:00	3600	58.3	75.4	37.8	93.7	68.0	63.2	49.2	39.3

Site LT1 Maui Butterfly Farm, Butterfly Pavilion - 820 Olowalu Village Rd

Daytime Hours (7:00AM to 5:00PM)  
 Evening Hours (5:00PM to 10:00PM)  
 Nighttime Hours (10:00PM to 7:00AM)

WSP 2023

TABLE B-1B. Site LT1 - Hourly Noise Measured Levels



WSP 2023



TABLE B-2A. Site LT2 - Hourly Noise Measured Levels

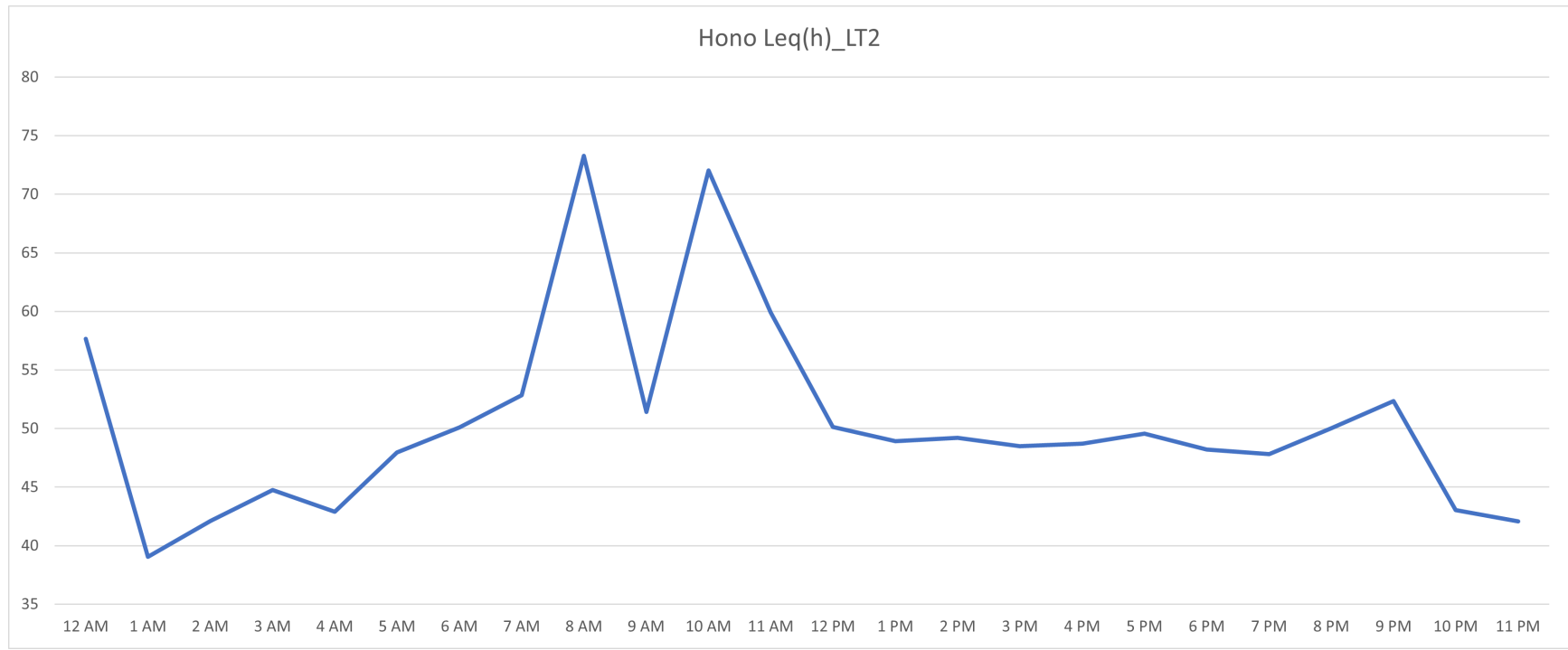
Site	Location	Number	Date	Time	Duration	Leq	Lmax	Lmin	Peak	L(1)	L(10)	L(50)	L(90)
Hono_LT2	Adjacent to 255 Luawai St	LT2	21-Jun-23	0:00:00	3600	57.7	65.6	38.0	85.5	63.0	62.4	53.2	38.5
Hono_LT2	Adjacent to 255 Luawai St	LT2	21-Jun-23	1:00:00	3600	39.1	47.4	38.0	72.1	41.9	39.9	38.8	38.2
Hono_LT2	Adjacent to 255 Luawai St	LT2	21-Jun-23	2:00:00	3600	42.1	61.5	38.0	77.2	51.0	44.3	39.6	38.3
Hono_LT2	Adjacent to 255 Luawai St	LT2	21-Jun-23	3:00:00	3600	44.7	61.5	38.0	82.0	54.2	47.8	40.0	38.3
Hono_LT2	Adjacent to 255 Luawai St	LT2	21-Jun-23	4:00:00	3600	42.9	56.8	38.0	86.0	52.3	46.3	39.7	38.3
Hono_LT2	Adjacent to 255 Luawai St	LT2	21-Jun-23	5:00:00	3600	48.0	68.4	38.6	86.1	59.5	49.4	43.2	40.0
Hono_LT2	Adjacent to 255 Luawai St	LT2	21-Jun-23	6:00:00	3600	50.1	71.1	39.5	85.0	61.4	50.1	43.6	40.9
Hono_LT2	Adjacent to 255 Luawai St	LT2	21-Jun-23	7:00:00	3600	52.8	70.4	39.3	87.1	64.7	55.9	46.3	41.4
Hono_LT2	Adjacent to 255 Luawai St	LT2	21-Jun-23	8:00:00	3600	73.3	92.5	40.1	115.6	87.6	73.4	58.9	44.3
Hono_LT2	Adjacent to 255 Luawai St	LT2	21-Jun-23	9:00:00	3600	51.4	74.9	40.9	91.0	62.1	53.4	46.7	43.5
Hono_LT2	Adjacent to 255 Luawai St	LT2	21-Jun-23	10:00:00	3600	72.0	92.1	41.8	104.9	87.2	62.6	49.0	44.6
Hono_LT2	Adjacent to 255 Luawai St	LT2	21-Jun-23	11:00:00	3600	59.9	88.7	39.7	100.5	70.2	52.8	45.5	41.8
Hono_LT2	Adjacent to 255 Luawai St	LT2	21-Jun-23	12:00:00	3600	50.1	67.5	39.6	83.6	59.7	53.7	46.1	41.6
Hono_LT2	Adjacent to 255 Luawai St	LT2	20-Jun-23	13:00:00	3600	49.2	69.7	42.0	83.2	56.4	51.3	47.4	44.4
Hono_LT2	Adjacent to 255 Luawai St	LT2	20-Jun-23	14:00:00	3600	48.5	67.7	40.9	81.9	56.4	50.4	47.0	44.4
Hono_LT2	Adjacent to 255 Luawai St	LT2	20-Jun-23	15:00:00	3600	48.7	66.8	40.6	79.4	57.1	50.3	47.0	44.3
Hono_LT2	Adjacent to 255 Luawai St	LT2	20-Jun-23	16:00:00	3600	49.6	77.4	41.0	105.9	55.9	50.1	46.6	44.0
Hono_LT2	Adjacent to 255 Luawai St	LT2	20-Jun-23	17:00:00	3600	48.2	73.7	39.6	89.2	51.8	48.1	45.8	42.8
Hono_LT2	Adjacent to 255 Luawai St	LT2	20-Jun-23	18:00:00	3600	47.8	65.3	39.0	88.9	58.2	50.3	44.4	41.0
Hono_LT2	Adjacent to 255 Luawai St	LT2	20-Jun-23	19:00:00	3600	50.0	59.2	38.6	81.4	58.0	53.9	47.1	40.5
Hono_LT2	Adjacent to 255 Luawai St	LT2	20-Jun-23	20:00:00	3600	52.3	66.6	38.7	85.5	62.0	56.7	44.9	39.5
Hono_LT2	Adjacent to 255 Luawai St	LT2	20-Jun-23	21:00:00	3600	43.0	57.8	38.5	71.2	48.8	45.0	42.0	40.1
Hono_LT2	Adjacent to 255 Luawai St	LT2	20-Jun-23	22:00:00	3600	42.1	49.6	38.0	66.2	47.2	45.3	40.9	38.4
Hono_LT2	Adjacent to 255 Luawai St	LT2	20-Jun-23	23:00:00	3600	46.8	74.0	38.1	87.4	59.6	43.3	39.2	38.2

Site LT2 Adjacent to 255 Luawai St

	Daytime Hours (7:00AM to 5:00PM)
	Evening Hours (5:00PM to 10:00PM)
	Nighttime Hours (10:00PM to 7:00AM)

WSP 2023

TABLE B-2B. Site LT2 - Hourly Noise Measured Levels



WSP 2023



TABLE B-3A. Site LT3 - Hourly Noise Measured Levels

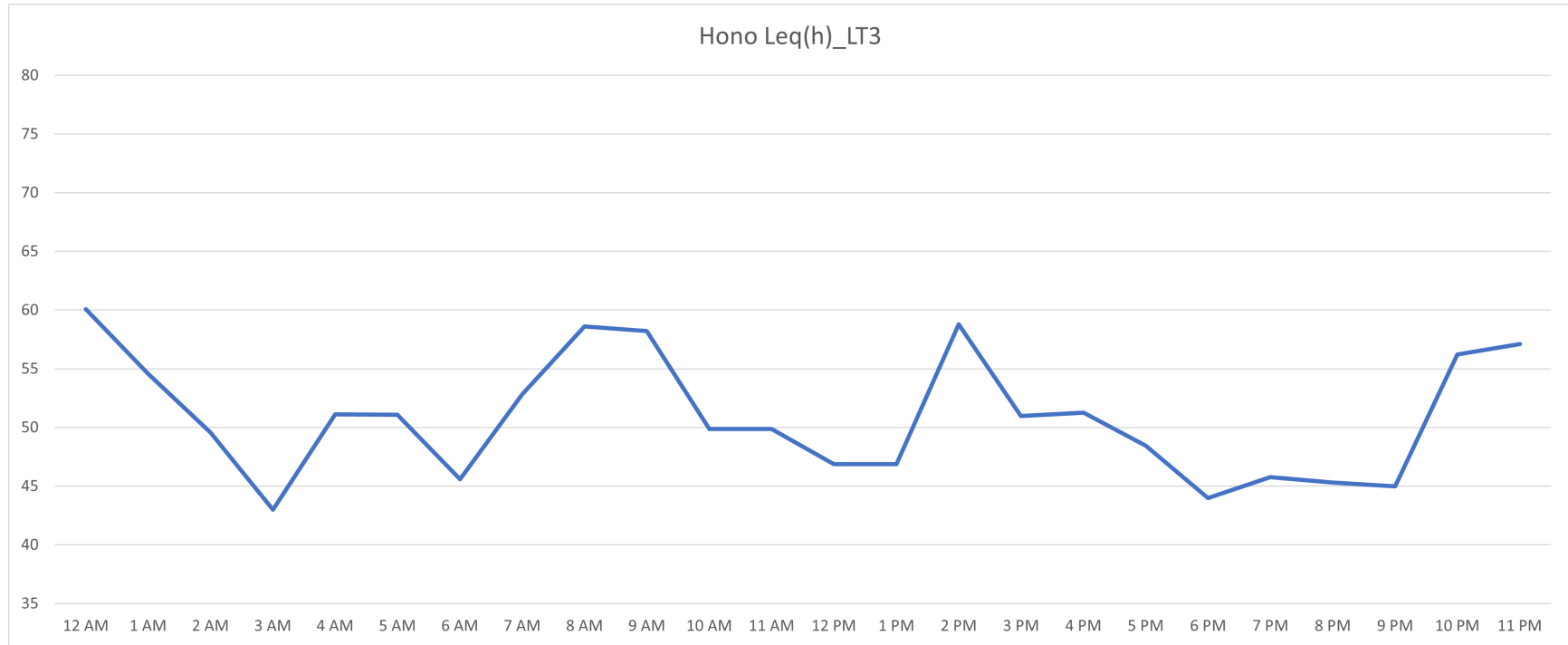
Site	Location	Number	Date	Time	Duration	Leq	Lmax	Lmin	Peak	L(1)	L(10)	L(50)	L(90)
Hono_LT3	Peeki'i Place Terminus	LT3	22-Jun-23	0:00:00	3600	60.1	76.3	44.8	92.3	68.1	63.5	57.5	52.4
Hono_LT3	Peeki'i Place Terminus	LT3	22-Jun-23	1:00:00	3600	54.6	66.7	42.9	92.4	62.8	58.1	52.1	47.6
Hono_LT3	Peeki'i Place Terminus	LT3	22-Jun-23	2:00:00	3600	49.6	67.4	37.5	91.6	60.9	53.1	42.4	38.4
Hono_LT3	Peeki'i Place Terminus	LT3	22-Jun-23	3:00:00	3600	43.0	59.6	37.1	92.3	55.6	43.9	38.4	37.3
Hono_LT3	Peeki'i Place Terminus	LT3	22-Jun-23	4:00:00	3600	51.1	65.7	37.2	86.1	62.1	55.8	41.6	37.8
Hono_LT3	Peeki'i Place Terminus	LT3	22-Jun-23	5:00:00	3600	51.1	67.7	39.3	85.1	60.9	54.1	47.3	42.2
Hono_LT3	Peeki'i Place Terminus	LT3	22-Jun-23	6:00:00	3600	45.6	64.2	38.8	81.8	54.5	47.9	42.8	40.4
Hono_LT3	Peeki'i Place Terminus	LT3	22-Jun-23	7:00:00	3600	52.8	72.7	38.6	94.7	63.2	56.6	45.2	40.7
Hono_LT3	Peeki'i Place Terminus	LT3	22-Jun-23	8:00:00	3600	58.6	73.7	39.1	93.6	69.2	62.8	51.7	42.2
Hono_LT3	Peeki'i Place Terminus	LT3	22-Jun-23	9:00:00	3600	58.2	74.4	39.0	99.8	69.3	62.9	47.9	41.1
Hono_LT3	Peeki'i Place Terminus	LT3	22-Jun-23	10:00:00	3600	49.9	66.8	39.2	93.4	60.2	53.3	44.6	40.6
Hono_LT3	Peeki'i Place Terminus	LT3	22-Jun-23	11:00:00	3600	46.9	63.4	38.7	88.9	58.2	49.1	42.2	39.8
Hono_LT3	Peeki'i Place Terminus	LT3	22-Jun-23	12:00:00	3600	58.8	72.3	38.9	93.0	69.2	63.4	52.4	41.7
Hono_LT3	Peeki'i Place Terminus	LT3	21-Jun-23	13:00:00	3600	51.0	67.9	39.2	85.3	61.2	54.0	47.1	42.4
Hono_LT3	Peeki'i Place Terminus	LT3	21-Jun-23	14:00:00	3600	51.3	71.8	38.3	89.9	61.9	53.9	46.2	40.6
Hono_LT3	Peeki'i Place Terminus	LT3	21-Jun-23	15:00:00	3600	48.4	62.9	38.1	88.3	59.1	51.5	44.3	40.8
Hono_LT3	Peeki'i Place Terminus	LT3	21-Jun-23	16:00:00	3600	44.0	63.0	37.8	91.1	50.9	45.7	42.3	39.5
Hono_LT3	Peeki'i Place Terminus	LT3	21-Jun-23	17:00:00	3600	45.8	60.9	37.5	82.9	54.7	49.6	41.7	38.6
Hono_LT3	Peeki'i Place Terminus	LT3	21-Jun-23	18:00:00	3600	45.3	64.1	37.9	85.2	54.4	48.1	42.1	39.1
Hono_LT3	Peeki'i Place Terminus	LT3	21-Jun-23	19:00:00	3600	45.0	61.3	37.0	92.4	56.1	48.1	40.0	37.5
Hono_LT3	Peeki'i Place Terminus	LT3	21-Jun-23	20:00:00	3600	56.2	74.5	38.1	90.6	66.2	59.6	50.7	42.6
Hono_LT3	Peeki'i Place Terminus	LT3	21-Jun-23	21:00:00	3600	57.1	69.6	38.1	92.3	66.4	61.3	52.9	41.5
Hono_LT3	Peeki'i Place Terminus	LT3	21-Jun-23	22:00:00	3600	57.6	69.2	41.6	96.8	65.7	61.3	55.1	48.4
Hono_LT3	Peeki'i Place Terminus	LT3	21-Jun-23	23:00:00	3600	55.7	68.6	37.8	87.9	65.0	60.2	51.1	40.1

Site LT3 Peeki'i Place Terminus

Daytime Hours (7:00AM to 5:00PM)  
 Evening Hours (5:00PM to 10:00PM)  
 Nighttime Hours (10:00PM to 7:00AM)

WSP 2023

TABLE B-3B. Site LT3 - Hourly Noise Measured Levels



WSP 2023



## APPENDIX C – FIELD INSTRUMENTATION CALIBRATION CERTIFICATES

Appendix C presents calibration certificates from annual laboratory calibration of all field instrumentation used to collect noise measurement data for the Honoapi'ilani Highway Project traffic noise analysis.



**CERTIFICATE OF CALIBRATION**  
**# 27333-5**  
**FOR LARSON DAVIS**  
**PRECISION INTEGRATING AND LOGGING SOUND**  
**LEVEL METER**

Model <b>820</b>	Serial No. <b>1194</b>
	ID No. <b>N/A</b>
With Microphone Model <b>2560</b>	Serial No. <b>3150</b>
With Preamplifier Model <b>PRM828</b>	Serial No. <b>1681</b>
Customer: <b>WSP USA</b>	P.O. No. <b>Admin Home 1828</b>
<b>Seattle, WA 98154</b>	

was tested and met Larson Davis specifications at the points tested and  
 as outlined in ANSI S1.4-1983 Type 1; IEC 651-1979 Type 1

on **24 AUG 2022** BY **HAROLD LYNCH**  
**Service Manager**

As received and as left condition: Within Specification.  
 Re-calibration due on: **24 AUG 2023**

Certified References*				
Mfg.	Type	Serial No.	Cal Date	Due Date
B&K	1051	1846829	08 SEP 2021	08 SEP 2022
B&K	2636	1601487	16 MAY 2022	16 MAY 2023
B&K	4226	3274134	30 NOV 2021	30 NOV 2022
B&K	4231	2094472	15 FEB 2022	15 FEB 2023
HP	34401A	US36071531	25 MAY 2022	25 MAY 2023
HP	3458A	2823A17713	20 SEP 2021	20 SEP 2022

Performed in Compliance with ANSI, NCSL Z-540-1, 1994  
 and ISO 17025, ISO 9001:2015 Certification NQA No. 11252  
 \*References are traceable to NIST (National Institute of Standards and Technology).

Note: For calibration data see enclosed pages.  
 The data represent both "as found" and "as left" condition.

Reference Test Procedure: **ACCT Procedure 812-820 Version 3.5.1.**

Temperature <b>23°C</b>	Relative Humidity <b>39 %</b>	Barometric Pressure <b>984.36 hPa</b>
----------------------------	----------------------------------	--

*Note: This calibration report shall not be reproduced, except in full, without written consent by Odin Metrology, Inc.*

Signed:

**ODIN METROLOGY, INC.**  
 CALIBRATION OF SOUND & VIBRATION INSTRUMENTATION  
 3533 OLD CONEJO ROAD, SUITE 125 THOUSAND OAKS CA 91320  
 PHONE: (805) 375-0830 FAX: (805) 375-0405





**Odin Metrology, Inc.**  
 Calibration of Sound & Vibration Instruments

Certificate Number: **27333-7**

## Certificate of Calibration for Larson Davis 1/2" Random Incidence Microphone

This calibration is performed by comparison with measurement reference standard microphone:

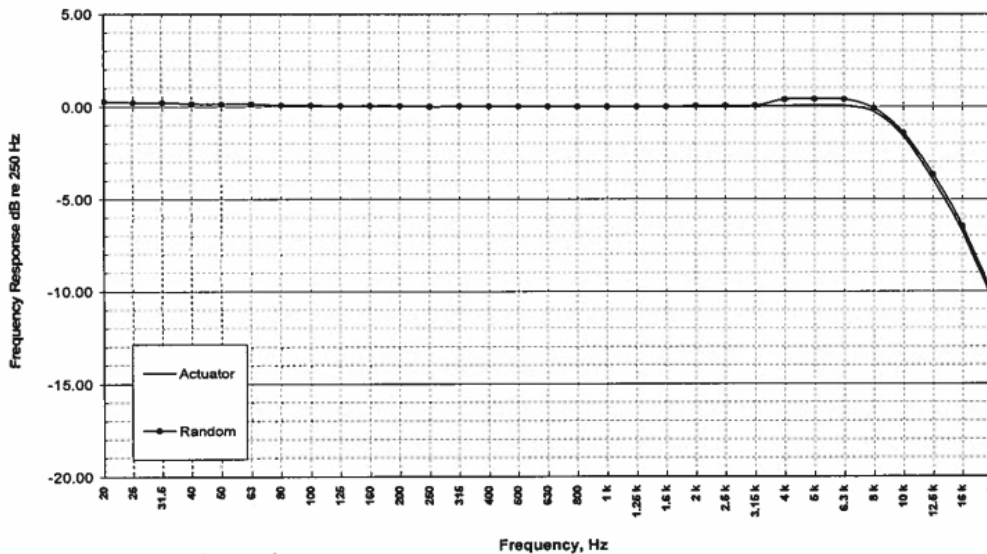
REFERENCE STANDARDS	
Type No.	4134/JA0825
Serial No.	1866524
Calibrated by	DANAK
Cal Date	23 SEP 2021
Due Date	23 SEP 2023

Type no. **2560**  
 Serial no. **3150**  
 With preamplifier type no. **N/A**  
 Preamplifier Serial no. **N/A**  
 Submitted by **WSP USA**  
**Seattle, WA 98154**  
 Purchase order no. **Admin Home 1828**  
 Asset no. **N/A**

- a) Estimated uncertainty of comparison: ± 0.05 dB
- b) Estimated uncertainty of reference microphone: ± 0.04 dB
- c) Total uncertainty:  $\sqrt{a^2 + b^2} = \pm 0.064$  dB
- d) Expanded uncertainty (coverage factor  $k = 2$  for 95% confidence level): ± 0.13 dB

PERFORMANCE DATA		
Open circuit sensitivity at 1,013 hPa, 23°C, 50% RH, 251.2 Hz	-26.31	dB re 1 V/Pa
	48.39	mV/Pa
System sensitivity (with preamplifier) at 251.2 Hz	N/A	dB re 1 V/Pa
	N/A	mV/Pa

**Microphone Frequency Response Type 2560  
 S/N 3150 : Measured 25 Aug 2022**



Calibration performed by *Harold Lynch*

Harold Lynch, Service Manager

CONDITION OF TEST		
Ambient Pressure	988.38	hPa
Temperature	23	°C
Relative Humidity	39	%
Polarization Voltage	200	V
Frequency	251.2	Hz
Date of Calibration	25 AUG 2022	
Re-calibration due on	25 AUG 2023	

**ODIN METROLOGY, INC.**  
 3533 OLD CONEJO ROAD, SUITE 125  
 THOUSAND OAKS, CA 91320  
 PHONE: (805) 375-0830; FAX: (805) 375-0405

The calibration data is both "as found" and "as final." At the time of calibration, this microphone was found to be within the manufacturer's specifications. Calibration Procedure: OM-P-1008-Microphone Rev. 1.2 20130618.

This calibration is traceable to DANAK/DPLA No. M2.10-1478-2.1 and through inter-laboratory comparisons to NIST Test Number: 683/289533-17. \*See page 2 Traceability.

Note: This calibration report shall not be reproduced, except in full, without written consent of Odin Metrology, Inc.

**CERTIFICATE OF CALIBRATION**  
**# 27333-1**  
**FOR LARSON DAVIS**  
**INTEGRATING SOUND LEVEL METER**

Model **720** Serial No. **0161**  
 With 3/8" electret microphone ID No. **N/A**  
 Serial No. **B1087**

Customer: **WSP USA** P.O. No. **Admin Home 1828**  
**Seattle, WA 98154**

was tested to Larson Davis specifications at the points tested and  
 as outlined in ANSI S1.4-1983 Type 2; IEC 651-1979 Type 2

on **24 AUG 2022** BY **HAROLD LYNCH**  
**Service Manager**

As received and as left condition: Within Specifications.  
 Re-calibration due on: **24 AUG 2023**

Certified References*				
Mfg.	Type	Serial No.	Cal Date	Due Date
B&K	4134	1315901	16 FEB 2022	16 FEB 2023
B&K	4226	3274134	30 NOV 2021	30 NOV 2022
HP	34401A	3146A48348	16 OCT 2021	16 OCT 2022

Calibration System operates in conformance to ANSI/ NCSL Z540-1, 1994  
 and ISO 17025, ISO 9001:2015 Certification NQA No. 11252  
 \*References are traceable to NIST (National Institute of Standards and Technology).

Note: For calibration data see enclosed pages.  
 The data represent both "as found" and "as left" conditions.

Reference Test Procedure: <b>Odin Metrology Procedure for Larson Davis 720.</b> <i>Uncertainty of Reference 4226 in Pressure:</i> 31.5 Hz-4k Hz: ± .20 dB 4k Hz-8k Hz: ± .25 dB <i>Uncertainty of ANSI Type 2 S.L.M.:</i> 31.5 Hz-2k Hz: ± 2 dB 2k Hz-4k Hz: ± 2.5 dB 4k Hz-5k Hz: ± 3.0 dB 5k Hz-6.3k Hz: ± 3.5 dB 6.3k Hz-8k Hz: ± 4.5 dB Uncertainty Ratio: > 4:1
---

Temperature <b>23°C</b>	Relative Humidity <b>39 %</b>	Barometric Pressure <b>984.36 hPa</b>
----------------------------	----------------------------------	--

Note: This calibration report shall not be reproduced, except in full, without written consent by Odin Metrology, Inc.  
 Signed: *Harold Lynch*

**ODIN METROLOGY, INC.**  
 CALIBRATION OF SOUND & VIBRATION INSTRUMENTATION  
 3533 OLD CONEJO ROAD, SUITE 125 THOUSAND OAKS CA 91320  
 PHONE: (805) 375-0830 FAX: (805) 375-0405



**CERTIFICATE OF CALIBRATION**  
**# 27333-2**  
**FOR LARSON DAVIS**  
**INTEGRATING SOUND LEVEL METER**

Model <b>720</b>	Serial No. <b>0514</b>
With 3/8" electret microphone	ID No. <b>N/A</b>
	Serial No. <b>B4105</b>
Customer: <b>WSP USA</b> Seattle, WA <b>98154</b>	P.O. No. <b>Admin Home 1828</b>

was tested to Larson Davis specifications at the points tested and  
 as outlined in ANSI S1.4-1983 Type 2; IEC 651-1979 Type 2

on **24 AUG 2022** BY **HAROLD LYNCH**  
 Service Manager

As received and as left condition: Within Specifications.  
 Re-calibration due on: **24 AUG 2023**

Certified References*				
Mfg.	Type	Serial No.	Cal Date	Due Date
B&K	4134	1315901	16 FEB 2022	16 FEB 2023
B&K	4226	3274134	30 NOV 2021	30 NOV 2022
HP	34401A	3146A48348	16 OCT 2021	16 OCT 2022
Calibration System operates in conformance to ANSI/ NCSL Z540-1, 1994 and ISO 17025, ISO 9001:2015 Certification NQA No. 11252 *References are traceable to NIST (National Institute of Standards and Technology).				

Note: For calibration data see enclosed pages.  
 The data represent both "as found" and "as left" conditions.

Reference Test Procedure: <b>Odin Metrology Procedure for Larson Davis 720.</b> Uncertainty of Reference 4226 in Pressure: 31.5 Hz-4k Hz: ± .20 dB 4k Hz-8k Hz: ± .25 dB Uncertainty of ANSI Type 2 S.L.M.: 31.5 Hz-2k Hz: ± 2 dB 2k Hz-4k Hz: ± 2.5 dB 4k Hz-5k Hz: ± 3.0 dB 5k Hz-6.3k Hz: ± 3.5 dB 6.3k Hz-8k Hz: ± 4.5 dB Uncertainty Ratio: > 4:1
---

Temperature <b>23°C</b>	Relative Humidity <b>39 %</b>	Barometric Pressure <b>984.36 hPa</b>
----------------------------	----------------------------------	--

Note: This calibration report shall not be reproduced, except in full, without written consent by Odin Metrology, Inc.

Signed: *Harold Lynch*

**ODIN METROLOGY, INC.**  
 CALIBRATION OF SOUND & VIBRATION INSTRUMENTATION  
 3533 OLD CONEJO ROAD, SUITE 125 THOUSAND OAKS CA 91320  
 PHONE: (805) 375-0830 FAX: (805) 375-0405



**CERTIFICATE OF CALIBRATION**  
**# 27333-3**  
**FOR LARSON DAVIS**  
**INTEGRATING SOUND LEVEL METER**

Model **720** Serial No. **0634**  
 With 3/8" electret microphone ID No. **N/A**  
 Serial No. **B8330**  
 Customer: **WSP USA** P.O. No. **Admin Home 1828**  
**Seattle, WA 98154**

was tested to Larson Davis specifications at the points tested and  
 as outlined in ANSI S1.4-1983 Type 2; IEC 651-1979 Type 2

on **24 AUG 2022** BY **HAROLD LYNCH**  
**Service Manager**

As received and as left condition: Within Specifications.  
 Re-calibration due on: **24 AUG 2023**


Certified References*				
Mfg.	Type	Serial No.	Cal Date	Due Date
B&K	4134	1315901	16 FEB 2022	16 FEB 2023
B&K	4226	3274134	30 NOV 2021	30 NOV 2022
HP	34401A	3146A48348	16 OCT 2021	16 OCT 2022

Calibration System operates in conformance to ANSI/ NCSL Z540-1, 1994  
 and ISO 17025, ISO 9001:2015 Certification NQA No. 11252  
 \*References are traceable to NIST (National Institute of Standards and Technology).

Note: For calibration data see enclosed pages.  
 The data represent both "as found" and "as left" conditions.

Reference Test Procedure: **Odin Metrology Procedure for Larson Davis 720.**  
 Uncertainty of Reference 4226 in Pressure:  
 31.5 Hz-4k Hz: ± 20 dB 4k Hz-8k Hz: ± 25 dB  
 Uncertainty of ANSI Type 2 S.L.M.: 31.5 Hz-2k Hz: ± 2 dB  
 2k Hz-4k Hz: ± 2.5 dB 4k Hz-5k Hz: ± 3.0 dB 5k Hz-6.3k Hz: ± 3.5 dB 6.3k Hz-8k Hz: ± 4.5 dB  
 Uncertainty Ratio: > 4:1

Temperature	Relative Humidity	Barometric Pressure
<b>23°C</b>	<b>39 %</b>	<b>984.36 hPa</b>

Note: This calibration report shall not be reproduced, except in full, without written consent by Odin Metrology, Inc.  
 Signed: 

**ODIN METROLOGY, INC.**  
 CALIBRATION OF SOUND & VIBRATION INSTRUMENTATION  
 3533 OLD CONEJO ROAD, SUITE 125 THOUSAND OAKS CA 91320  
 PHONE: (805) 375-0830 FAX: (805) 375-0405



<p><b>Odin Metrology, Inc.</b>          Calibration of Sound &amp; Vibration Instruments</p>	<p>Certificate Number: <b>27333-4</b></p>																						
<h2 style="margin: 0;">Certificate of Calibration for Larson Davis Calibrator</h2>																							
<p>This calibration is performed by comparison with measurement reference standard microphone:</p>																							
<table border="1" style="width: 100%; border-collapse: collapse;"> <tr><td>Type No.</td><td>4134</td></tr> <tr><td>Serial No.</td><td>1315901</td></tr> <tr><td>Calibrated by</td><td>HL</td></tr> <tr><td>Cal Date</td><td>16 FEB 2022</td></tr> <tr><td>Due Date</td><td>16 FEB 2023</td></tr> </table>	Type No.	4134	Serial No.	1315901	Calibrated by	HL	Cal Date	16 FEB 2022	Due Date	16 FEB 2023	<table style="width: 100%;"> <tr><td>Calibrator type</td><td><b>CAL200</b></td></tr> <tr><td>Serial no.</td><td><b>2239</b></td></tr> <tr><td>Submitted by</td><td><b>WSP USA</b></td></tr> <tr><td></td><td><b>Seattle, WA 98154</b></td></tr> <tr><td>Purchase order no.</td><td><b>Admin Home 1828</b></td></tr> <tr><td>Asset no.</td><td><b>N/A</b></td></tr> </table>	Calibrator type	<b>CAL200</b>	Serial no.	<b>2239</b>	Submitted by	<b>WSP USA</b>		<b>Seattle, WA 98154</b>	Purchase order no.	<b>Admin Home 1828</b>	Asset no.	<b>N/A</b>
Type No.	4134																						
Serial No.	1315901																						
Calibrated by	HL																						
Cal Date	16 FEB 2022																						
Due Date	16 FEB 2023																						
Calibrator type	<b>CAL200</b>																						
Serial no.	<b>2239</b>																						
Submitted by	<b>WSP USA</b>																						
	<b>Seattle, WA 98154</b>																						
Purchase order no.	<b>Admin Home 1828</b>																						
Asset no.	<b>N/A</b>																						
<p>a) Estimated uncertainty of comparison: <math>\pm 0.05</math> dB          b) Estimated uncertainty of calibration service for standard pistonphone: <math>\pm 0.06</math> dB          c) Total uncertainty: <math>\sqrt{a^2 + b^2} = \pm 0.08</math> dB          d) Expanded uncertainty (coverage factor <math>k = 2</math> for 95% confidence level): <math>\pm 0.16</math> dB</p>																							
<p>This acoustic calibrator has been calibrated using standards with values traceable to the National Institute of Standards and Technology. This calibration is traceable to NIST Test Number <b>683/289533-17</b>.</p>																							
<table border="1" style="width: 100%; border-collapse: collapse;"> <thead> <tr><th colspan="3">CONDITION OF TEST</th></tr> </thead> <tbody> <tr><td>Ambient Pressure</td><td><b>988.38</b></td><td>hPa</td></tr> <tr><td>Temperature</td><td><b>23</b></td><td>°C</td></tr> <tr><td>Relative Humidity</td><td><b>39</b></td><td>%</td></tr> <tr><td>Date of Calibration</td><td colspan="2"><b>25 AUG 2022</b></td></tr> <tr><td>Re-calibration due on</td><td colspan="2"><b>25 AUG 2023</b></td></tr> </tbody> </table>		CONDITION OF TEST			Ambient Pressure	<b>988.38</b>	hPa	Temperature	<b>23</b>	°C	Relative Humidity	<b>39</b>	%	Date of Calibration	<b>25 AUG 2022</b>		Re-calibration due on	<b>25 AUG 2023</b>					
CONDITION OF TEST																							
Ambient Pressure	<b>988.38</b>	hPa																					
Temperature	<b>23</b>	°C																					
Relative Humidity	<b>39</b>	%																					
Date of Calibration	<b>25 AUG 2022</b>																						
Re-calibration due on	<b>25 AUG 2023</b>																						
<p>The calibration of this acoustic calibrator was performed using a test system conforming to the requirements of ANSI/NC SLZ540-1, 1994, ISO 17025, and ISO 9001:2015, Certification NQA No. 11252.</p>																							
<p>Calibration procedure: <b>OMP-1001-Acoustic_Calibrator, Rev. 1.0 20130522</b></p>																							
<p>Calibration performed by <i>Harold Lynch</i></p>																							
<p>Harold Lynch, Service Manager</p>																							
<p><b>ODIN METROLOGY, INC.</b>          3533 OLD CONEJO ROAD, SUITE 125          THOUSAND OAKS, CA 91320          PHONE: (805) 375-0830; FAX: (805) 375-0405</p>																							
<table border="1" style="width: 100%; border-collapse: collapse;"> <thead> <tr><th colspan="3">PERFORMANCE AS RECEIVED</th></tr> </thead> <tbody> <tr><td>Frequency</td><td><b>1000.0</b></td><td>Hz</td></tr> <tr><td>SPL (94 dB)</td><td><b>93.95</b></td><td>dB</td></tr> <tr><td>SPL (114 dB)</td><td><b>113.97</b></td><td>dB</td></tr> <tr><td>Distortion (at 94 dB)</td><td><b>0.3</b></td><td>%</td></tr> <tr><td>Battery Voltage</td><td><b>9.3</b></td><td>V</td></tr> </tbody> </table>		PERFORMANCE AS RECEIVED			Frequency	<b>1000.0</b>	Hz	SPL (94 dB)	<b>93.95</b>	dB	SPL (114 dB)	<b>113.97</b>	dB	Distortion (at 94 dB)	<b>0.3</b>	%	Battery Voltage	<b>9.3</b>	V				
PERFORMANCE AS RECEIVED																							
Frequency	<b>1000.0</b>	Hz																					
SPL (94 dB)	<b>93.95</b>	dB																					
SPL (114 dB)	<b>113.97</b>	dB																					
Distortion (at 94 dB)	<b>0.3</b>	%																					
Battery Voltage	<b>9.3</b>	V																					
<p>Was adjustment performed? <span style="float: right;"><b>No</b></span>          Were batteries replaced? <span style="float: right;"><b>No</b></span></p>																							
<table border="1" style="width: 100%; border-collapse: collapse;"> <thead> <tr><th colspan="3">FINAL PERFORMANCE</th></tr> </thead> <tbody> <tr><td>Frequency</td><td><b>1000.0</b></td><td>Hz</td></tr> <tr><td>SPL (94 dB)</td><td><b>93.95</b></td><td>dB</td></tr> <tr><td>SPL (114 dB)</td><td><b>113.97</b></td><td>dB</td></tr> <tr><td>Distortion (at 94 dB)</td><td><b>0.3</b></td><td>%</td></tr> </tbody> </table>		FINAL PERFORMANCE			Frequency	<b>1000.0</b>	Hz	SPL (94 dB)	<b>93.95</b>	dB	SPL (114 dB)	<b>113.97</b>	dB	Distortion (at 94 dB)	<b>0.3</b>	%							
FINAL PERFORMANCE																							
Frequency	<b>1000.0</b>	Hz																					
SPL (94 dB)	<b>93.95</b>	dB																					
SPL (114 dB)	<b>113.97</b>	dB																					
Distortion (at 94 dB)	<b>0.3</b>	%																					
<p>Note: This calibrator was <b>within</b> manufacturer's specifications as received.</p>																							
<p><small>Note: This calibration report shall not be reproduced, except in full, without written consent of Odin Metrology, Inc.</small></p>																							
<p>Page 1 of 2          Doc. Rev. 18 Jun 2020</p>																							

## APPENDIX D – MODELED TRAFFIC DATA

Appendix D provides traffic data modeled for the traffic noise analysis. Traffic data includes traffic volumes, speeds, and vehicle mix by roadway for worst-hour Existing 2019, 2045 No Build, and 2045 Build traffic data provided by the Honoapi'ilani Highway Traffic Team.



TABLE D-1. Existing Conditions 2023 Modeled Traffic Noise Levels – PM Peak Hour (Olowalu)

2023 Peak Hour Traffic Turning Movements		XXX AM Peak Hour		XXX PM Peak Hour		combined		combined		combined											
						A 5 25		A 49 25 M 0 25		A 39 25 M 0 25											
		A 2 25	M 0	H 0	A 2 25	M 0	H 0	A 31 25	M 1 25	H 0	A 7 25	M 0	H 0	A 32 25	M 1 25	H 0	A 6 25	M 0	H 0		
		1		1		2		2		3		3		3		3		3			
		Olowalu Recyclin & Refuse		Olowalu Recyclin & Refuse		Olowalu Recyclin & Refuse		Olowalu Genera North		Olowalu Genera North		Olowalu Genera North-Middle		Olowalu Genera North-Middle		Olowalu Genera North-Middle		Olowalu Genera North-Middle			
		981	1134	966	1135	959	1173	947	1149	967	1185	947	1149	967	1185	947	1149	967	1185	947	1149
TNM	A	### 45	### 45	### 45	### 45	### 45	### 45	### 45	### 45	### 45	### 45	### 45	### 45	### 45	### 45	### 45	### 45	### 45	### 45	### 45	### 45
TNM	M	28 45	28 45	28 45	28 45	28 45	28 45	28 45	28 45	28 45	28 45	28 45	28 45	28 45	28 45	28 45	28 45	28 45	28 45	28 45	28 45
TNM	H	11 45	11 45	11 45	11 45	11 45	11 45	11 45	11 45	11 45	11 45	11 45	11 45	11 45	11 45	11 45	11 45	11 45	11 45	11 45	11 45
		981	1134	966	1135	959	1173	947	1149	967	1185	947	1149	967	1185	947	1149	967	1185	947	1149
Honoapiilani		1	16	12	6	1	4	1	4	1	4	1	4	1	4	1	4	1	4	1	4
Hwy		1	16	12	6	1	4	1	4	1	4	1	4	1	4	1	4	1	4	1	4
TNM	A	1113 45	1152 1028	A 1113 35	1131 1042	A ### 35	1135 1043	A ### 35	1135 1043	A ### 35	1135 1043	A ### 35	1135 1043	A ### 35	1135 1043	A ### 35	1135 1043	A ### 35	1135 1043	A ### 35	1135 1043
TNM	M	29 45	29 45	M 29 35	29 35	M 28 35	28 35	M 28 35	28 35	M 28 35	28 35	M 28 35	28 35	M 28 35	28 35	M 28 35	28 35	M 28 35	28 35	M 28 35	28 35
TNM	H	12 45	12 45	H 12 35	12 35	H 11 35	11 35	H 11 35	11 35	H 11 35	11 35	H 11 35	11 35	H 11 35	11 35	H 11 35	11 35	H 11 35	11 35	H 11 35	11 35
		1153	1044	1153	1036	1143	1048	1132	1043	1136	1047	1132	1043	1136	1047	1132	1043	1136	1047	1132	1043
		976	1177	982	1173	977	1171	977	1169	981	1168	977	1169	981	1168	977	1169	981	1168	977	1169
		A 1136 35	9 27	A 1132 45	2 0	A 1128 45	2 0	A 1128 45	2 0	A 1128 45	2 0	A 1128 45	2 0	A 1128 45	2 0	A 1128 45	2 0	A 1128 45	2 0	A 1128 45	2 0
		M 29 35	9 27	M 29 45	0 0	M 29 45	0 0	M 29 45	0 0	M 29 45	0 0	M 29 45	0 0	M 29 45	0 0	M 29 45	0 0	M 29 45	0 0	M 29 45	0 0
		H 12 35	9 27	H 12 45	0 0	H 12 45	0 0	H 12 45	0 0	H 12 45	0 0	H 12 45	0 0	H 12 45	0 0	H 12 45	0 0	H 12 45	0 0	H 12 45	0 0
		976	1177	982	1173	977	1171	977	1169	981	1168	977	1169	981	1168	977	1169	981	1168	977	1169
		14	13	14	13	14	13	14	13	14	13	14	13	14	13	14	13	14	13	14	13
		A ### 35	1099 1014	A 1087 45	1122 1027	A 1083 45	1118 1025	A 1083 45	1118 1025	A 1083 45	1118 1025	A 1083 45	1118 1025	A 1083 45	1118 1025	A 1083 45	1118 1025	A 1083 45	1118 1025	A 1083 45	1118 1025
		M 28 35	28 35	M 28 45	28 45	M 28 45	28 45	M 28 45	28 45	M 28 45	28 45	M 28 45	28 45	M 28 45	28 45	M 28 45	28 45	M 28 45	28 45	M 28 45	28 45
		H 11 35	11 35	H 11 45	11 45	H 11 45	11 45	H 11 45	11 45	H 11 45	11 45	H 11 45	11 45	H 11 45	11 45	H 11 45	11 45	H 11 45	11 45	H 11 45	11 45
		1113	1027	1126	1025	1122	1027	1122	1028	1118	1025	1122	1028	1118	1025	1122	1028	1118	1025	1122	1028
		976	1177	982	1173	977	1171	977	1169	981	1168	977	1169	981	1168	977	1169	981	1168	977	1169
		A 35 25	A 18 25	A 2 25	A 0	A 2 25	A 0	A 2 25	A 0	A 2 25	A 0	A 2 25	A 0	A 2 25	A 0	A 2 25	A 0	A 2 25	A 0	A 2 25	A 0
		M 1 25	M 0	M 0	M 0	M 0	M 0	M 0	M 0	M 0	M 0	M 0	M 0	M 0	M 0	M 0	M 0	M 0	M 0	M 0	M 0
		H 0	H 0	H 0	H 0	H 0	H 0	H 0	H 0	H 0	H 0	H 0	H 0	H 0	H 0	H 0	H 0	H 0	H 0	H 0	H 0
		6	6	7	7	8	8	8	8	8	8	8	8	8	8	8	8	8	8	8	8
		Luawai Street		Olowalu Village Middle		Olowalu Village Middle		Olowalu Village South		Olowalu Village South		Olowalu Village South		Olowalu Village South		Olowalu Village South		Olowalu Village South		Olowalu Village South	

TABLE D-2. Existing Conditions 2023 Modeled Traffic Noise Levels – PM Peak Hour (Ukumehame)

Section	Speed	Location	Direction	Vehicle Type	Count	Distance	Modeling Parameters	Modeling Results (A, M, H)
5	35 mph	Dlowalu Genera	Middle	Northbound	Combined	68	25	A: 68, M: 25
					A	24	25	A: 24, M: 1, H: 0
					M	1	25	M: 1, H: 0
				Southbound	Combined	58	25	A: 58, M: 25
					A	21	25	A: 21, M: 1, H: 0
					M	1	25	M: 1, H: 0
	35 mph	Dlowalu Genera	South	Northbound	A	28	25	A: 28, M: 1, H: 0
					M	1	25	M: 1, H: 0
					H	0	25	H: 0
				Southbound	A	30	25	A: 30, M: 1, H: 0
					M	1	25	M: 1, H: 0
					H	0	25	H: 0
6	55 mph	Ehehene Street	Northbound	Combined	18	25	A: 18, M: 25	
				A	10	25	A: 10, M: 0, H: 0	
				M	0	25	M: 0, H: 0	
				Southbound	A	5	25	A: 5, M: 0, H: 0
					M	0	25	M: 0, H: 0
					H	0	25	H: 0
	45 mph	Pohaku Aeko Street	Northbound	A	5	25	A: 5, M: 0, H: 0	
				M	0	25	M: 0, H: 0	
				H	0	25	H: 0	
				Southbound	A	11	25	A: 11, M: 0, H: 0
					M	0	25	M: 0, H: 0
					H	0	25	H: 0
45 mph	Ukumehame Firing Range	Northbound	A	1	25	A: 1, M: 0, H: 0		
			M	0	25	M: 0, H: 0		
			H	0	25	H: 0		
			Southbound	A	0	25	A: 0, M: 0, H: 0	
				M	0	25	M: 0, H: 0	
				H	0	25	H: 0	
Traffic Volumes and Distances: Section 5: 962, 954, 955, 954, 966 Section 6: 979, 958, 959, 906, 910, 955, 957 Distances: 1161, 1140, 1158, 1167, 1169, 1171, 1183, 1179, 1160, 1162, 1177, 1176, 1118, 1140, 1137, 1146, 1142, 1125, 1125								
Modeling Results Summary: Section 5: A: 1098, M: 28, H: 11, 1126, 29, 12, 1071, 28, 11, 1136, 29, 12, 1086, 28, 11 Section 6: A: 1142, M: 30, H: 12, 1138, 29, 12, 1136, 45, 1135, 45, 1100, 29, 11, 1106, 29, 11, 1102, 29, 11, 1086, 28, 11								





TABLE D-3. No Build 2045 Modeled Traffic Noise Levels – PM Peak Hour (Olowalu)

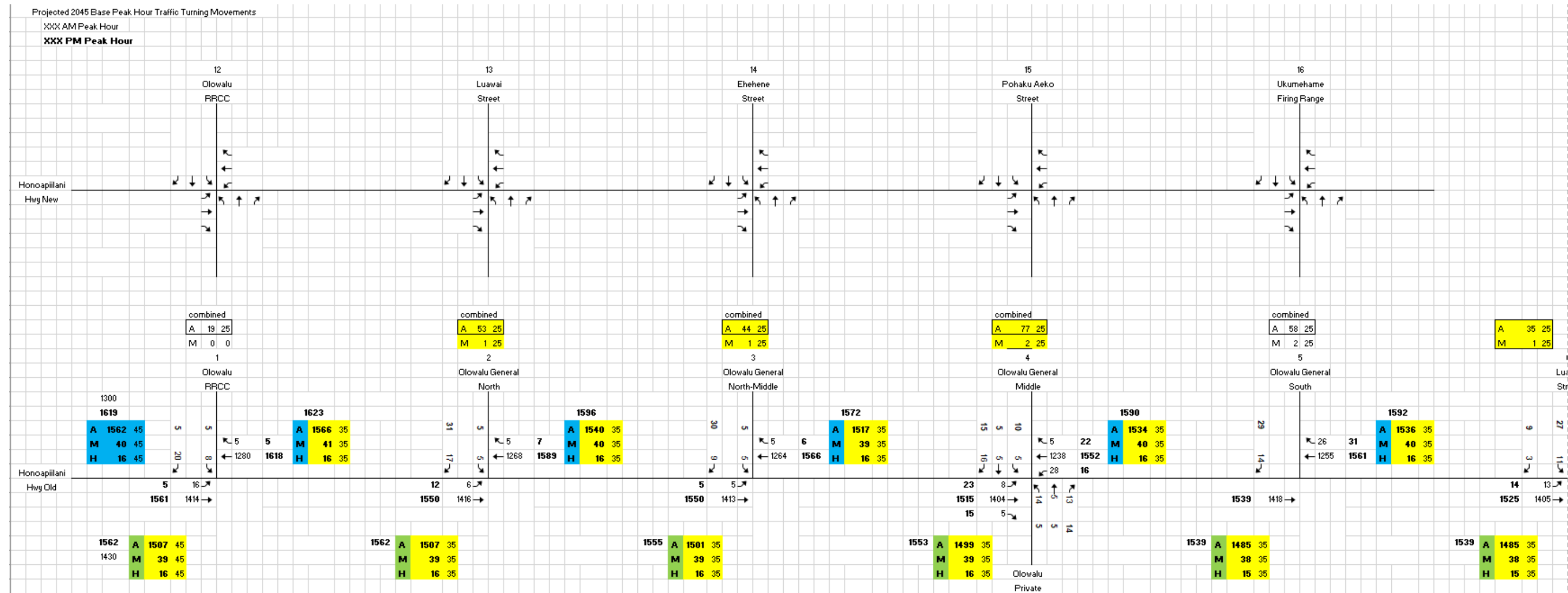


TABLE D-4. No Build 2045 Modeled Traffic Noise Levels – PM Peak Hour (Ukumehame)

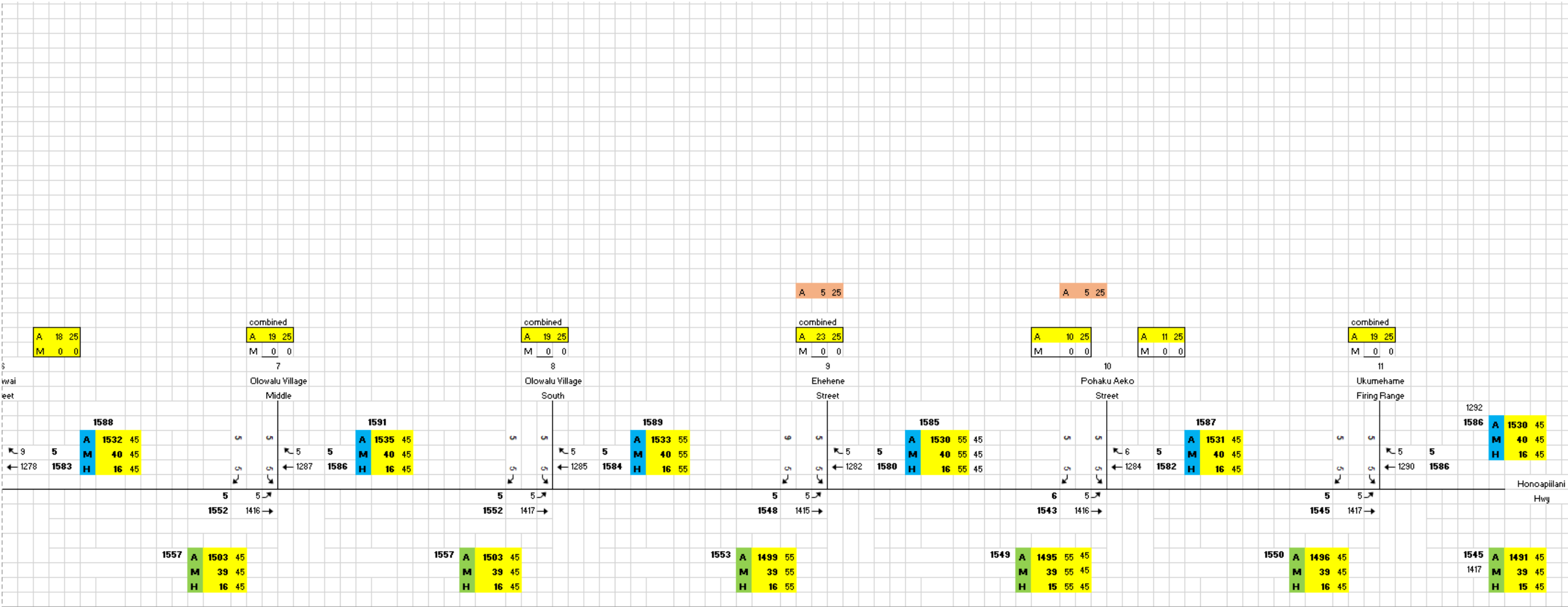




TABLE D-5. Build Alternative 1 2045 Modeled Traffic Noise Levels – PM Peak Hour (Olowalu)

2045 Alternative 1 Total		A 5 25			A 5 25						
XXX AM Peak Hour	combined	A 40 25	A 23 25	A 18 25	A 14 25	A 14 25	A 15 25				
XXX PM Peak Hour	A 30 25	M 1 25	M 1 25	M 0 0	M 0 0	M 0 0	M 0 0				
		H 0 0	H 0 0	H 0 0	H 0 0	H 0 0	H 0 0				
12 Olowalu RRCC		13 Luwai Street			14 Ehehene Street			15 Pohaku Aeko Street			
Each Lane	A 641 45	Each Lane	A 641 45	Each Lane	A 622 45	Each Lane	A 623 45	Each Lane	A 623 45		
	M 17 45		M 17 45		M 16 45		M 16 45		M 16 45		
	H 7 45		H 7 45		H 6 45		H 6 45		H 6 45		
Honoapi'ilani Hwy New	1299	1235	1198	1286	1281	1282	1291				
Each Lane	A 632 45	Each Lane	A 627 45	Each Lane	A 625 45	Each Lane	A 623 45				
	M 16 45		M 16 45		M 16 45		M 16 45				
	H 7 45		H 7 45		H 6 45		H 6 45				
1 Olowalu RRCC		2 Olowalu General North		3 Olowalu General North-Middle		4 Olowalu General Middle		5 Olowalu General South		6 Luwai Street	
Each Lane	A 10 45	Each Lane	A 10 35	Each Lane	A 36 35	Each Lane	A 72.4 35	Each Lane	A 128 35	Each Lane	A 138 25
	M 0 45		M 0 35		M 0.9 35		M 1.88 35		M 3 35		M 4 25
	H 0 45		H 0 35		H 0.4 35		H 0.75 35		H 1 35		H 1 25
Honoapi'ilani Hwy Old	10	10	37	75	109	143					

TABLE D-6. Build Alternative 1 2045 Modeled Traffic Noise Levels – PM Peak Hour (Ukumehame)

										Each Lane A 623 45 M 16 45 H 6 45			Each Lane A 623 45 M 16 45 H 6 45						
										A 10 25		A 10 25		A 10 25		A 10 25		A 10 25	
7		8		9		10		11											
Olowalu Village Middle		Olowalu Village South		Ehehene Street		Pohaku Aeko Street		Ukumehame Firing Range											
5 5		5 5		5 5		5 5		5 5		5 5		5 5		5 5		5 5			
A 10 45		A 10 55		A 10 55		A 10 45		A 10 45								A 10 45			
5 5		5 5		5 5		5 5		5 5		5 5		5 5		5 5		5 5			
5 5		5 5		5 5		5 5		5 5		5 5		5 5		5 5		5 5			
A 10 45		A 10 45		A 10 55		A 10 55 45		A 10 45		A 10 45		A 10 45		A 10 45		A 10 45			
10 M 0 45		10 M 0 45		10 M 0 55		10 M 0 55 45		10 M 0 45		10 M 0 45		10 M 0 45		10 M 0 45		10 M 0 45			
H 0 45		H 0 45		H 0 55		H 0 55 45		H 0 45		H 0 45		H 0 45		H 0 45		H 0 45			



TABLE D-7. Build Alternative 2 2045 Modeled Traffic Noise Levels – PM Peak Hour (Olowalu)

2045 Alternative 2 Total		A 5 25		A 5 25	
XXX AM Peak Hour		A 40 25	A 23 25	A 18 25	A 14 25
XXX PM Peak Hour	combined	M 1 25	M 1 25	M 0 0	M 0 0
	A 30 25	H 0 0	H 0 0	H 0 0	H 0 0

Location	12 Olowalu	13 Luawai	14 Ekehene	15 Pohaku Aeko	16 Ukumehame
1325					
1316					
Each Lane	A 639 45	A 635 45	A 622 45	A 623 45	A 625 45
	M 17 45	M 16 45	M 16 45	M 16 45	M 16 45
	H 7 45	H 7 45	H 6 45	H 6 45	H 6 45
Honoapiilani	1049 1282	1024 1225	1074 1281	1076 1282	1084 1286
Hwy New	5 5	14 13	5 5	6 5	5 5
	1282 1162	1244 1149	1286 1170	1281 1171	1283 1172
	18 23	34 14	5 5	5 5	5 5
Each Lane	A 630 45	A 623 45	A 625 45	A 623 45	A 624 45
	M 16 45	M 16 45	M 16 45	M 16 45	M 16 45
	H 7 45	H 6 45	H 6 45	H 6 45	H 6 45

Location	1 Olowalu	2 Olowalu General North	3 Olowalu General North-Middle	4 Olowalu General Middle	5 Olowalu General South	6 Luawai Street
1325						
1316						
Each Lane	A 10 45	A 51 35	A 11 22	A 17 17	A 19 19	A 87 35
	M 1 35	M 1 35	M 1 35	M 2 35	M 2 35	M 2 35
	H 1 35	H 1 35	H 1 35	H 1 35	H 1 35	H 1 35
Honoapiilani	29 46	7 13	5 5	7 30	17 21	88 5
Hwy Old	5 5	6 5	5 5	15 4	10 9	92 58
	5 5	38 25	57 34	54 27	74 47	5 5
	10 10	44 42	10 10	10 10	97 94	97 94
	M 0 45	M 1 35	M 0 45	M 0 45	M 2 35	M 2 35
	H 0 45	H 0 35	H 0 45	H 0 45	H 1 35	H 1 35

TABLE D-8. Build Alternative 2 2045 Modeled Traffic Noise Levels – PM Peak Hour (Ukumehame)

	7 Olowalu Village Middle				8 Olowalu Village South				9 Ehehene Street				10 Pohaku Aeko Street				11 Ukumehame Firing Range				
	S	S	A 10 45		S	S	A 10 55		S	S	A 10 55		S	S	A 10 45		S	S	A 10 45		
	↖ 5	↖ 5			↖ 5	↖ 5			↖ 5	↖ 5			↖ 5	↖ 5			↖ 5	↖ 5			
	↗ 5	↗ 5			↗ 5	↗ 5			↗ 5	↗ 5			↗ 5	↗ 5			↗ 5	↗ 5			
	↘ 5	↘ 5			↘ 5	↘ 5			↘ 5	↘ 5			↘ 5	↘ 5			↘ 5	↘ 5			
	↙ 5	↙ 5			↙ 5	↙ 5			↙ 5	↙ 5			↙ 5	↙ 5			↙ 5	↙ 5			
	5	5			5	5			5	5			5	5			5	5			
	6	5			5	5			5	5			5	5			5	5			
	A 11 35				A 10 45				A 10 55				A 10 55 45				A 10 45				A 10 45
11	M 0 35				M 0 45				M 0 55				M 0 55 45				M 0 45				M 0 45
	H 0 35				H 0 45				H 0 55				H 0 55 45				H 0 45				H 0 45



TABLE D-9. Build Alternative 3 2045 Modeled Traffic Noise Levels – PM Peak Hour (Olowalu)

2045 Alternative 3 Total		A 5 25		A 5 25 Paekii Place		
XXX AM Peak Hour	combined	A 40 25	A 23 25	A 18 25	A 14 25	
XXX PM Peak Hour	A 30 25	M 1 25	M 1 25	M 0 0	M 0 0	
		H 0 0	H 0 0	H 0 0	H 0 0	
	12 Olowalu RRCC	13 Luawai Street	14 Ekehene Street	15 Pohaku Aeko Street	16 Ukumehame Firing Range	
Each Lane	A 639 45 M 17 45 H 7 45	A 635 45 M 16 45 H 7 45	A 622 45 M 16 45 H 6 45	A 623 45 M 16 45 H 6 45	A 625 45 M 16 45 H 6 45	
Honoapiʻilani	1049 1282 27 29	1024 1225 44 60	1074 1281 5 5	1076 1282 5 5	1084 1286 5 5	
Hwy New	5 5 1282 1162 18 23	14 13 1244 1149 34 14	5 5 1286 1170 5 5	6 5 1281 1171 5 5	5 5 1283 1172 5 5	
Each Lane	A 630 45 M 16 45 H 7 45	A 623 45 M 16 45 H 6 45	A 625 45 M 16 45 H 6 45	A 623 45 M 16 45 H 6 45	A 624 45 M 16 45 H 6 45	
					A 91 25 M 2 25 H 1 25	
					A 94 25 M 2 25 H 1 25	
	1 Olowalu RRCC	2 Olowalu General North	3 Olowalu General North-Middle	4 Olowalu General Middle	5 Olowalu General South	6 Luawai Street
Each Lane	A 10 45	A 51 35 M 1 35 H 1 35	A 22 7 M 26 37	A 17 7 M 16 28 H 21 21	A 19 17 M 21 69 H 1 35	A 10 45
Honoapiʻilani	44 29 5 5	11 21 7 23	11 22 5 26	8 17 5 16 0 21	10 19 5 39	88 5 85 5
Hwy Old	5 5 5 5	6 5 38 25	5 5 57 34	15 5 54 27 10 10	10 9 74 47	92 58 5 5
Each Lane	A 10 45 M 0 45 H 0 45	A 42 35 M 1 35 H 0 35				A 94 35 M 2 35 H 1 35
				Olowalu Private		



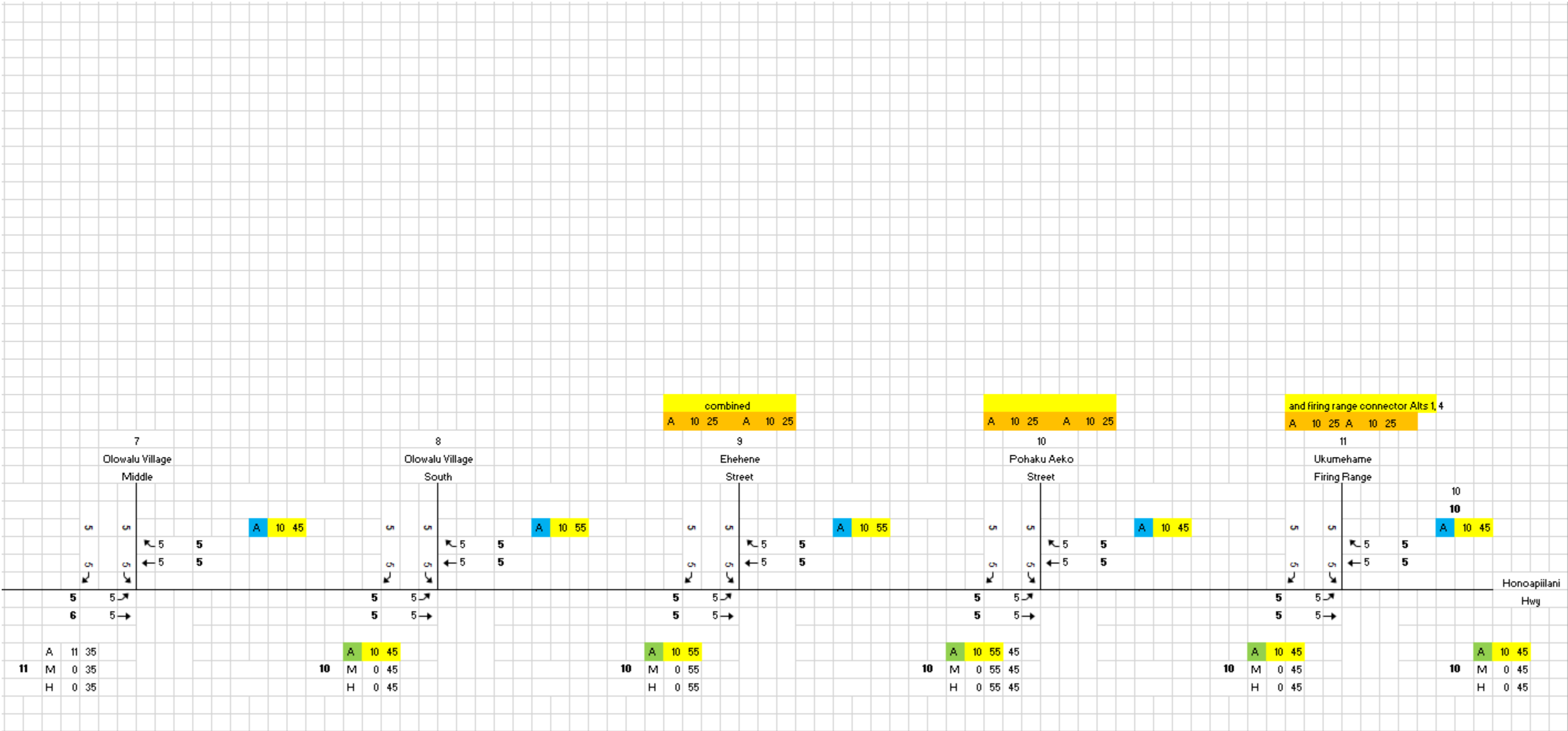




TABLE D-11. Build Alternative 4 2045 Modeled Traffic Noise Levels – PM Peak Hour (Olowalu)

2045 Alternative 4 Total		A 5 25		A 5 25 Paekii Place	
XXX AM Peak Hour	combined	A 40 25	A 23 25	A 18 25	A 14 25
XXX PM Peak Hour	A 30 25	M 1 25	M 1 25	M 0 0	M 0 0
		H 0 0	H 0 0	H 0 0	H 0 0
12 Olowalu RRCC		13 Luawai Street		14 Ekehene Street	
Each Lane	A 639 45	Each Lane	A 635 45	Each Lane	A 622 45
	M 17 45		M 16 45		M 16 45
	H 7 45		H 7 45		H 6 45
15 Pohaku Aeko Street				Each Lane A 623 45	
				M 16 45	
				H 6 45	
Honoapiʻilani		Honoapiʻilani		Honoapiʻilani	
Hwy New		Hwy New		Hwy New	
Each Lane	A 630 45	Each Lane	A 623 45	Each Lane	A 623 45
	M 16 45		M 16 45		M 16 45
	H 7 45		H 6 45		H 6 45
1 Olowalu RRCC		2 Olowalu General North		3 Olowalu General North-Middle	
Each Lane	A 10 45	Each Lane	A 51 35	Each Lane	A 10 45
	M 1 35		M 1 35		M 2 35
	H 1 35		H 1 35		H 1 35
4 Olowalu General Middle		5 Olowalu General South		6 Luawai Street	
Each Lane	A 87 35	Each Lane	A 10 45	Each Lane	A 94 25
	M 2 35		M 2 35		M 2 25
	H 1 35		H 1 35		H 1 25
Honoapiʻilani		Honoapiʻilani		Honoapiʻilani	
Hwy Old		Hwy Old		Hwy Old	
Each Lane	A 10 45	Each Lane	A 42 35	Each Lane	A 94 35
	M 0 45		M 1 35		M 2 35
	H 0 45		H 0 35		H 1 35
Olowalu Private					

TABLE D-12. Build Alternative 4 2045 Modeled Traffic Noise Levels – PM Peak Hour (Ukumehame)





## APPENDIX E – TRAFFIC NOISE MODELING DATA

TNM v2.5 files of all noise modeling files are provided electronically with the Final Noise Technical Report. Modeling files developed for this report are organized and labeled as shown in Table E-1.

TABLE E-1. **TNM File Names and Descriptions**

TNM FILE NAME	DESCRIPTION OF CONTENTS
HDOT_HonoHwy _TNM_Validations	File contains 10 files with modeled noise levels from measurement locations. Sites used for model validation are: Val_FM3 aligns with Measurement Site ST-3; Val_FM_5 aligns with Measurement Site ST-5; Val_FM7 aligns with Measurement Site ST-7; Val_FM_8 aligns with Measurement Site ST-8; Val_FM9 aligns with Measurement Site ST-9; Val_FM_10 aligns with Measurement Site ST-10.
HDOT_HonoHwy_TNM_Existing	File contains existing conditions modeled noise levels.
HDOT_HonoHwy_TNM_No Build	File contains future No Build modeled noise levels.
HDOT_HonoHwy_TNM_Alt1	File contains future Build Alternative 1 modeled noise levels.
HDOT_HonoHwy_TNM_Alt2	File contains future Build Alternative 2 modeled noise levels.
HDOT_HonoHwy_TNM_Alt3	File contains future Build Alternative 3 modeled noise levels.
HDOT_HonoHwy_TNM_Alt4	File contains future Build Alternative 4 modeled noise levels.
HDOT_HonoHwy _TNM_Alt4_Mitigation	File contains future Build Alternative 4, Noise Barrier 1 barrier evaluation.

Source: WSP, 2024.